

Emergency Signs and Escape Routes

 ecoglo®
VISIBLY BETTER

Solutions to meet NZBC Clause F8 Signs and Clause F6 Visibility in Escape Routes

New Zealand Catalogue



GET RID OF BATTERIES... FOREVER!

With Ecoglo Hybrid PL exit signs the batteries can be disposed of forever!

Ecoglo's technology is essentially a photonic storage device that replaces the battery. When combined with next generation LEDs it's the ultimate solution.

All Ecoglo exit signs are designed to meet NZBC F8/AS1.



 **ecoglo**[®]

VISIBLY BETTER

For more information see the
Hybrid Exit Sign Product Data Sheet

in this catalogue or

Email: info@ecoglo.com

Telephone: + 64 3 348 3781 www.ecoglo.co.nz



Contents	Page
Completed Ecoglo Projects.....	3-4
Company Profile.....	5
Ecoglo Exit Signs	6-60
Signs to meet NZBC F8.....	7-9
Mounting Brackets.....	10
S20 Exit Signs FAQs.....	11-12
F8 Flowcharts (How to check if Ecoglo Exit Signs will meet F8)....	13-14
F8/AS1 Compliance Checklists.....	15-16
F8/AS1 Maintenance Checklists.....	17-18
Ecoglo S20 Exit Signs Design Guide.....	19-38
Ecoglo Hybrid Exit Signs (Compliance with F8/AS1).....	39-40
Product Data Sheets (Signs).....	41-59
Safety Data Sheet (Signs).....	60
Ecoglo Escape Route Products	61-102
Escape Route Products to meet F6.....	62-64
Miscellaneous Products.....	65
Escape Route Products FAQs.....	66-67
F6 Flowchart (How to check if Ecoglo markings will meet F6).....	68-69
F6 Maintenance Checklist.....	70
Product Data Sheets (Escape Route Products).....	71-83
Safety Data Sheets (Escape Route Products).....	84-86
Designing your photoluminescent path marking system.....	87-102

Completed Projects Using Ecoglo Products

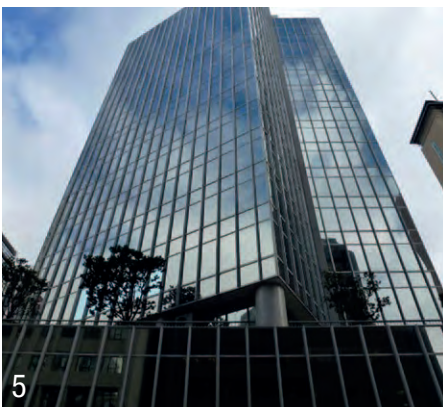

- 1. Christchurch Hospital
- 2. US Bank Tower, Los Angeles
- 3. Venetian Macao, Macau
- 4. Burj Khalifa, Dubai
- 5. ANZ Tower, Wellington
- 6. MCG Melbourne
- 7. Wellington Regional Hospital

 **ecoglo**[®]
VISIBLY BETTER

Ecoglo International Transit Projects



New York City Transit - 7th Avenue Station, Brooklyn



London Underground - Shepherds Bush Market Station



Marine Coastal Expressway - Singapore



MTR Corporation, Hong Kong - Yeung Long Station



Toronto Transit Commission - Bloor Street Station



Tokyo Subway



Cahill Tunnel - Sydney

Established in 1997, Ecoglo International is a New Zealand owned company with its head office and manufacturing plant located in Christchurch.

Ecoglo designs and manufactures highly durable photoluminescent (PL) Exit Signs and Escape Route Products to meet the exit sign requirements of New Zealand Building Code (NZBC) Clause F8 Signs, and the emergency lighting requirements of Clause F6 Visibility in Escape Routes.

Ecoglo is serious about sustainability and its standard signs and products are designed to utilise ambient light and therefore require no electricity, lamps or batteries, need only minimal maintenance, and can be readily recycled, making them extremely cost effective building solutions. The solutions are failsafe, operate immediately and will last the life of a building.

With many international building codes, including NZBC, supporting the use of new technologies which promote sustainable and cost effective emergency lighting systems, Ecoglo has recently focused on developing and increasing its range of exit signs. This range now includes an architectural series which offers sleekly designed signs to complement any interior space - and Ecoglo's hybrid sign.

There are situations where there is insufficient ambient light to charge photoluminescent exit signs, so Ecoglo's engineering team set about finding a solution to this problem. This has come in the form of Ecoglo's recently patented LED/PL hybrid exit sign. A breakthrough in power usage and storage, the hybrid sign is an ultra reliable, cost effective exit signage solution which can be used in any lighting scenario. Unlike electrical exit signs, the hybrid sign requires no batteries, and therefore has no battery disposal issues.

Ecoglo's patented products have been used worldwide in facilities as varied as the Melbourne Cricket Ground, Los Angeles' US Bank Tower, New York's Jazz at Lincoln Center, Singapore Supreme Court, Toronto's Eaton Centre, London's Bond St Underground Station and Dubai's 160 floor Burj Khalifa.

In New Zealand Ecoglo can be seen at Canterbury University, ANZ Tower (Wellington), Downtown Car Park (Auckland), Christchurch and Wellington Hospitals, new Bunnings stores, Eden Park, Viaduct Events Centre, Science Centre (Christchurch) as well as hundreds of warehouses, educational and public facilities, offices and health care buildings.



Ecoglo Exit Signs

 ecoglo®
VISIBLY BETTER

Surface Mounted Emergency S20 Exit Signs to meet **NZBC F8**



Exit

Exit straight on from here

Maximum Viewing Distance: 16 metres

Product No: S20-EX2313-16m

Size 230mm x 133mm



Pictogram

Exit straight on from here

Maximum Viewing Distance: 16 metres

Product No: S20-RM2916-16m

Size 290mm x 162mm

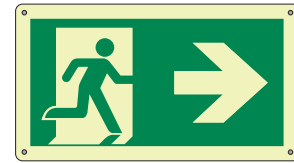

Pictogram Right

Exit right from here

Maximum Viewing Distance: 16 metres

Product No: S20-RMR2916-16m

Double Sided DSS20-RMD2916-16m

Size 290mm x 162mm



Exit

Exit straight on from here

Maximum Viewing Distance: 24 metres

Product No: S20-EX2916-24m

Size 290mm x 162mm



Pictogram

Exit straight on from here

Maximum Viewing Distance: 24 metres

Product No: S20-RM4223-24m

Size 420mm x 230mm

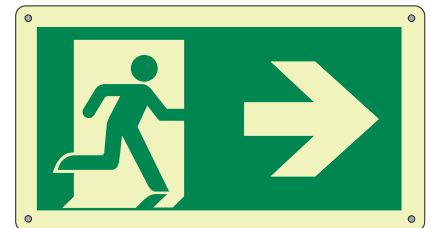

Pictogram Right

Exit right from here

Maximum Viewing Distance: 24 metres

Product No: S20-RMR4223-24m

Double Sided DSS20-RMD4223-24m

Size 420mm x 230mm



Pictogram Uni

Exit straight on from here

Maximum Viewing Distance: 16 metres

Product No: S20-RM1616UN-16m

Size 162mm x 162mm



Pictogram Hi Vis

Exit straight on from here

Maximum Viewing Distance: 16 metres

Product No: S20-RM2916HV-16m

Size 290mm x 162mm



Pictogram Left

Exit left from here

Maximum Viewing Distance: 16 metres

Product No: S20-RML2916-16m

Double Sided DSS20-RMD2916-16m

Size 290mm x 162mm



Pictogram Uni

Exit straight on from here

Maximum Viewing Distance: 24 metres

Product No: S20-RM2323UN-24m

Size 230mm x 230mm



Pictogram Hi Vis

Exit straight on from here

Maximum Viewing Distance: 24 metres

Product No: S20-RM4223HV-24m

Size 420mm x 230mm



Pictogram Left

Exit left from here

Maximum Viewing Distance: 24 metres

Product No: S20-RML4223-24m

Double Sided DSS20-RMD4223-24m

Size 420mm x 230mm

Surface Mounted Emergency S20 Exit Signs to meet NZBC F8

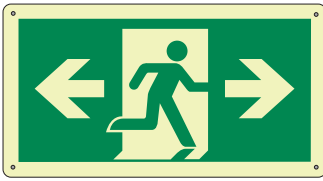

Pictogram Double Arrow

Exit right or left from here

Maximum Viewing Distance: 16 metres

Product No: S20-RMRL2916-16m

Double Sided: DSS20-RMRL2916-16m

Size 290mm x 162mm



Emergency Exit

Use this door only to exit in an emergency

Maximum Viewing Distance: 16 metres

Product No: S20-EE6128-16m

Size 610mm x 280mm

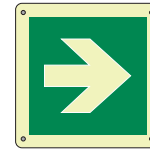

Arrow

Travel in this direction

Product No: S20-AR1313

Size 133mm x 133mm

For use with: S20-EX2313-16m

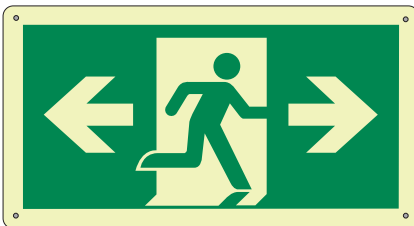

Pictogram Double Arrow

Exit right or left from here

Maximum Viewing Distance: 24 metres

Product No: S20-RMRL4223-24m

Double Sided: DSS20-RMRL4223-24m

Size 420mm x 230mm



Emergency Exit

Use this door only to exit in an emergency

Maximum Viewing Distance: 24 metres

Product No: S20-EE7835-24m

Size 785mm x 350mm

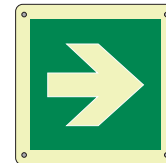

Arrow

Travel in this direction

Product No: S20-AR1616

Size 162mm x 162mm

For use with: S20-RM1616-16m and S20-EX2916-24m



Pictogram

Double Arrow Hi Vis

Exit right or left from here

Maximum Viewing Distance: 16 metres

Product No: S20-RMRL2916HV-16m

Double Sided: DSS20-RMRL2916HV-16m

Size 290mm x 162mm



No Exit

Do not use this door to exit in an emergency

Maximum Viewing Distance: 16 metres

Product No: S20-NE4113-16m

Size 410mm x 133mm

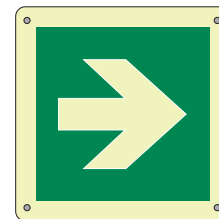

Arrow

Travel in this direction

Product No: S20-AR2323

Size 230mm x 230mm

For use with: S20-RM2323-24m



Accessible

Access and facilities for people with disabilities

Product No: S20-AC1616

Size 162mm x 162mm



Pictogram

Double Arrow Hi Vis

Exit right or left from here

Maximum Viewing Distance: 24 metres

Product No: S20-RMRL4223HV-24m

Double Sided: DSS20-RMRL4223HV-24m

Size 420mm x 230mm

Emergency Hybrid Exit Signs to meet **NZBC F8**



Surface Mount



Flag Mount



Ceiling Mount

Row and Seat Markers

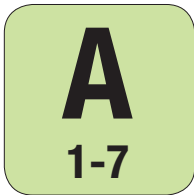

Row and Seat Marker

Guides people
to their seats

Product No: SQ90RSP
Size 90mmx90mm

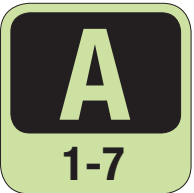

Row and Seat Marker

Guides people
to their seats

Product No: SQ90RSN
Size 90mmx90mm

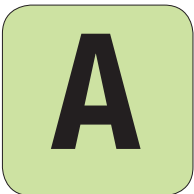

Row Marker

Guides people
to their Aisle

Product No: SQ90R
Size 90mmx90mm

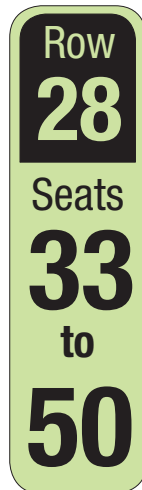

Row and Seat Marker

Guides people
to their seats

Product No: RE16045-RS
Size 160mmx45mm



Ellipse Marker

Individual seat number

Product No: EL187567
Size 18.7mmx56.7mm

Mounting Brackets

Standard Mounting Brackets



CEILING MOUNT



FLAG MOUNT

Architectural Mounting Brackets



CEILING MOUNT



FLAG MOUNT



SURFACE MOUNT

Chain Suspension for Signs

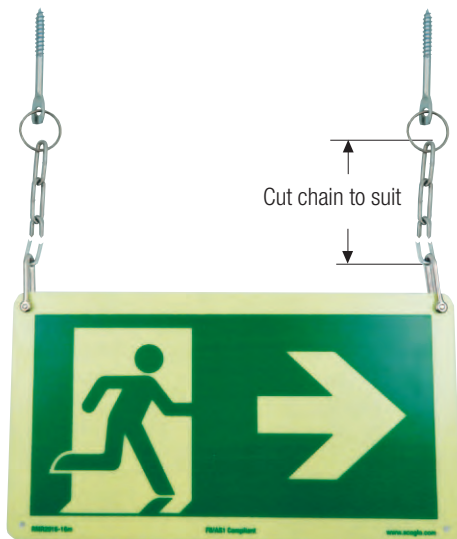

Q *How much do they cost?*

A Most commonly less than \$60+GST trade price, but signs that need to be seen from more than 16 metres cost more, and if standard brackets are required to mount the signs from a ceiling, or to protrude from a wall, the cost is an extra \$10 - \$20 depending on the size required. Ecoglo also offer a range of architectural brackets to complement any environment - please visit our website www.ecoglo.co.nz, or contact info@ecoglo.com for more information and pricing.

Q *Do they need an electrical light installed near them?*

A No, they are designed to make use of the existing light in the building.

Q *How long do they last?*

A A minimum of 30 years when installed indoors before there would be any measurable change in performance, and a minimum of 15 years outdoors for outdoor coated signs¹.

Q *What maintenance is required?*

A Make sure they are cleaned of dust or dirt build up. If the building doesn't need any other emergency lighting, in many cases Ecoglo S20 exit signs will not need to be part of the annual building WOF schedule.

Q *F8/AS1 requires that they be illuminated with a minimum of 100 lux to make sure they are charged ready for an emergency. What if there isn't 100 lux where the sign needs to be?*

A Ecoglo S20 exit signs are designed to work in most normal lighting situations. Ecoglo's professional engineer can design an alternative solution to meet F8 in situations where there is as little as 55 lux available. This is a free service. Contact Ecoglo (engineer@ecoglo.com) for details.

Q *Can LED lighting be used for charging Ecoglo S20 exit signs?*

A Yes, any lighting, including LEDs, with a colour temperature of 4000K or more, is suitable for charging Ecoglo S20 exit signs. 4000K or more is typical for schools, offices, commercial and industrial lighting, and most retail stores.

Q *Do the lights near the exit signs need to be turned on before the building is occupied?*

A No. Ecoglo S20 exit signs have been independently tested to confirm they meet the F8/AS1 luminance (brightness) requirement for Risk Group C buildings² after, at most, 5 minutes charging at 100 lux.

Q *What happens if there is a lights-out emergency in the first 5 minutes of occupation?*

A In most cases a sign will have sufficient residual charge from when there was light on it before, but even if the sign has become fully discharged and someone enters a dark space and turns on a light, the signs will meet the F8/AS1 brightness requirement for a longer evacuation time than the time since the light was turned on. By the time 5 minutes has elapsed the signs will have the full 30 minutes charge required for Risk Group C buildings.

Q *How reliable are they?*

A They have no moving parts or components that will need replacing. As long as they are installed where there are normal indoor light levels, and they are kept reasonably clean, and not physically damaged, they will be visible in an emergency for the time required by F8 and F6 for at least 30 years.

Q *Where are they made?*

A They are designed and manufactured in Christchurch, using a unique process that was developed locally, over twenty years ago.

Q *Where can they be used?*

A Ideal places are in building spaces that are normally occupied when the signs may need to be used, such as classrooms, offices, meeting rooms, retail spaces, factories, and warehouses. In these places if the space becomes dark, the occupier will turn on a light, making sure that the signs remain well charged. Ecoglo S20 exit signs can also be used in spaces that aren't normally occupied (such as corridors linking rooms and stairwells), but there needs to be a management process for making sure that the signs are always sufficiently charged when someone may need to use them. Contact Ecoglo for more details.

Q *Who can install them?*

A Anyone who knows how to put a screw into a wall, and knows where the exit signs need to be installed to meet F8.

Q *What are their environmental credentials?*

A They are made in New Zealand in a factory that uses electricity (from a supplier committed to sustainable electricity production) as its only energy source. The factory creates no commercial liquid effluent, and negligible air emissions. The signs have no replaceable parts which would need to be disposed of, and no cadmium or mercury. They normally don't require any electricity to be used to keep them charged. They have an extremely long life, and if for any reason they need to be disposed of, they can be included with other aluminium products for aluminium recycling.

Q *Can they be used outdoors?*

A Yes, they are designed to meet the rigours of long term outdoor exposure in our harsh Southern Hemisphere environment. No matter what the weather, they can meet the requirements of F8 for several hours after sunset, or 24/7 when the distance they need to be seen from is no more than half their rated viewing distance. Contact Ecoglo for specific details.

Q *Do Ecoglo photoluminescent exit signs meet AS 2293?*

A In 2017 Standards Australia decided that AS 2293 does not cover photoluminescent exit signs, only internally and externally illuminated exit signs. More importantly, Ecoglo photoluminescent exit signs do meet NZBC F8/AS1.

¹ Signs specially coated for outdoor conditions

² Almost all buildings with less than 1000 occupants are Risk Group C

F8/AS1 Flowchart

How to check if an Ecoglo S20 sign will meet F8/AS1

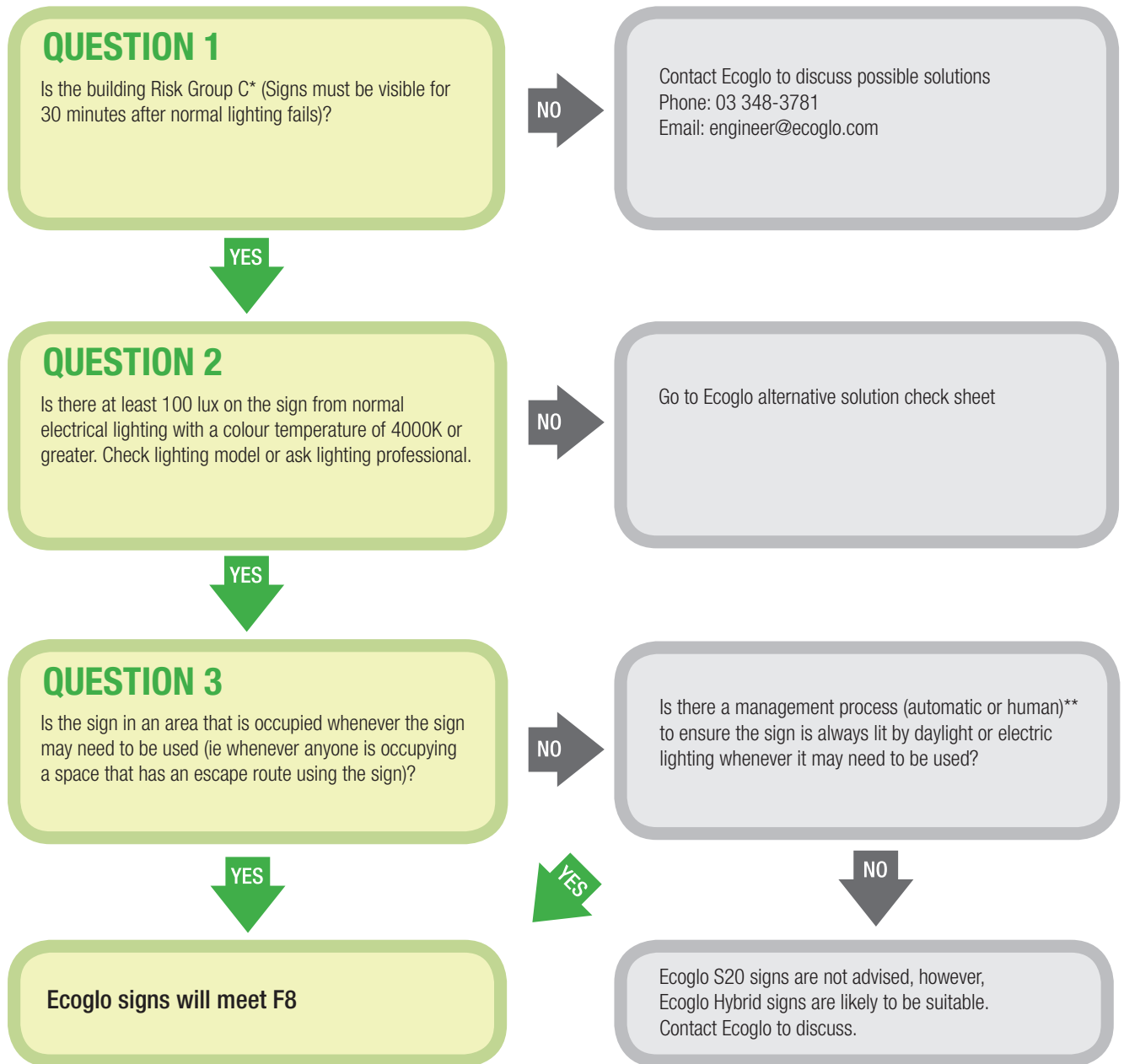

** Effective management processes include:

- Lighting is switched on whenever the building's security alarm system is de-activated;
- Lighting is switched on by a conservatively programmed timer;
- A master switch is turned on by the first occupier that turns on all the required lighting;
- Lighting is switched on manually (only suitable for staff-only areas- staff induction requires first occupier to switch on lighting, and clear instruction signs are permanently located by all relevant light switches);
- Signs are outdoors and required viewing distance is 50% of the signs rating.

* NZBC F6 definition for Risk Group C: a building with an evacuation time of less than 30 minutes, an occupant load no more than 1000, and whose occupants are not to remain in the building during an emergency.

F8 Alternative Solution Flowchart

How to check if an Ecoglo S20 sign will meet F8 with an Alternative Solution

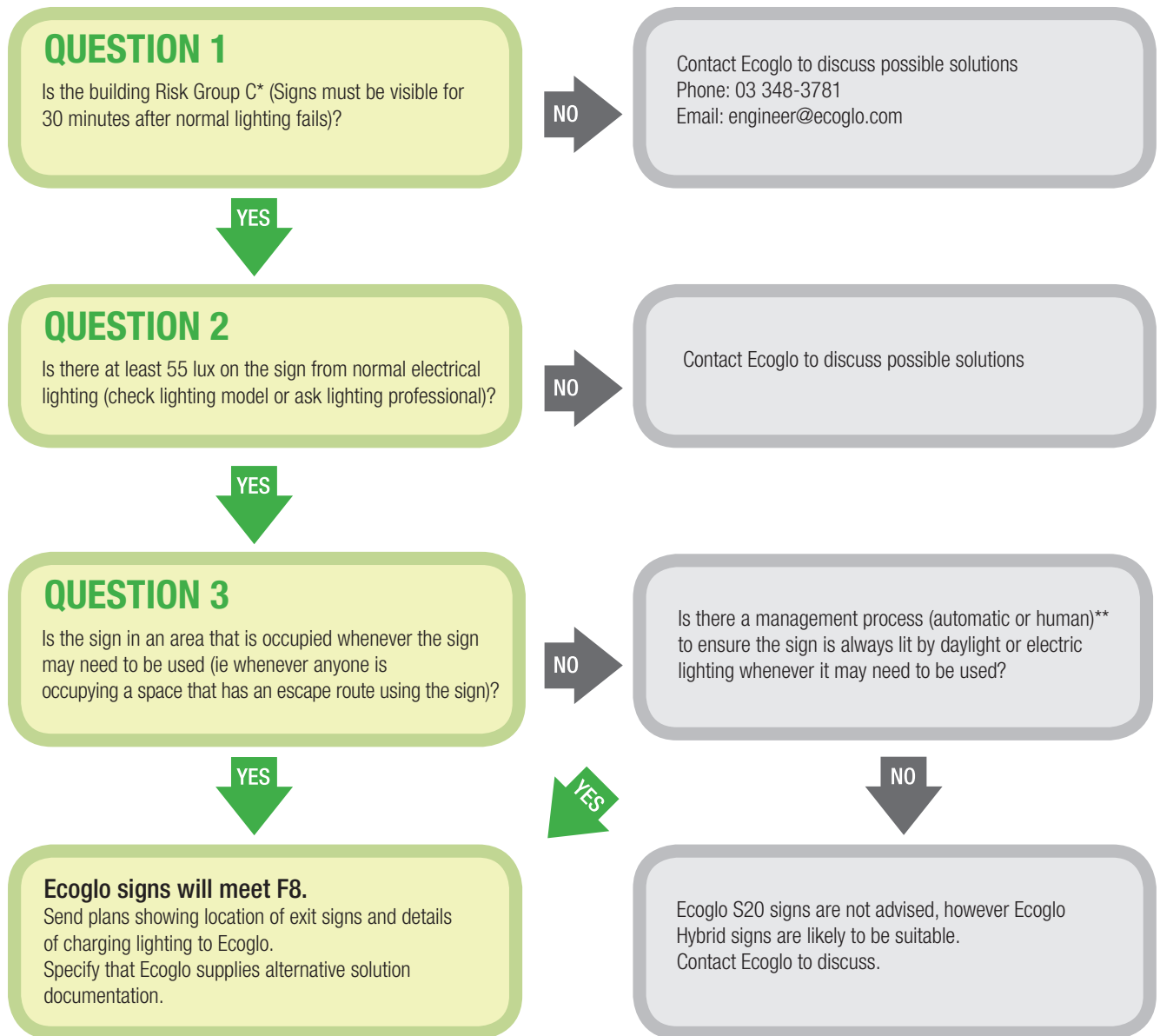

** Effective management processes include:

- Lighting is switched on whenever the building's security alarm system is de-activated;
- Lighting is switched on by a conservatively programmed timer;
- A master switch is turned on by the first occupier that turns on all the required lighting;
- Lighting is switched on manually (only suitable for staff-only areas - staff induction requires first occupier to switch on lighting, and clear instruction signs are permanently located by all relevant light switches);
- Signs are outdoors and required viewing distance is 50% of the signs rating.

* NZBC F6 definition for Risk Group C: a building with an evacuation time of less than 30 minutes, an occupant load no more than 1000, and whose occupants are not to remain in the building during an emergency.

F8/AS1 Compliance Checklist for Signs Installed Indoors

Ecoglo S20 signs meet the requirements of F8/AS1 because:

- The building is classified as Risk Group C* (requiring the signs to remain visible for 30 minutes after normal lighting fails).
- There is at least 100 lux on every sign from normal electrical lighting with a colour temperature of 4000K or greater.
- Every sign is in an area that is occupied whenever the sign may need to be used (so occupants will turn on the lights whenever there is insufficient natural light).
- The attached plan shows:
 - The location of each sign and its Ecoglo product code, and;
 - The lighting model maintained lux levels, or the lux readings taken from a light meter on site.

Note: Ecoglo Hybrid Signs are compliant with F8/AS1 - see NZL F8/AS1 HYU Compliance Report (available for download from www.ecoglo.co.nz)

Product luminance test reports, data sheets, installation instructions, and Ecoglo's recommended maintenance/checking procedures can be found on the Ecoglo website: www.ecoglo.co.nz

* NZBC F6 definition for Risk Group C: a building with an evacuation time of less than 30 minutes, an occupant load no more than 1000, and whose occupants are not to remain in the building during an emergency.

F8/AS1 Compliance Checklist for Signs Installed Outdoors

Ecoglo S20 signs meet the requirements of F8/AS1 because:

- The sign is installed outdoors, and the maximum distance it needs to be visible from is half the rated distance for the sign, therefore no artificial lighting is required to keep it charged.
- The attached plan shows:
 - The location of each sign and its Ecoglo product code.

Product luminance test reports, data sheets, installation instructions, and Ecoglo's recommended maintenance/checking procedures can be found on the Ecoglo website: www.ecoglo.co.nz

* NZBC F6 definition for Risk Group C: a building with an evacuation time of less than 30 minutes, an occupant load no more than 1000, and whose occupants are not to remain in the building during an emergency.

Recommended Maintenance Checking Procedure for Ecoglo S20 signs:

Monthly Maintenance Check *(to be carried out by the Owner or their appointed agent)* COMPLETED

- All signs are still configured as at installation and there is no material damage to any of the signs.
- All signs are clean from general dust build up and any other specific obscuring deposits.
- All signs are clearly visible and have not been covered up.
- All lights within 4m of internal S20 signs have been checked that the positions have not altered from design.
- All lights within 4m of internal S20 signs are in working order and clean.
- All automated lighting control systems are operational as per design.

Annual Inspection *(to be carried out by an IQP)* COMPLETED

- All signs are still configured as at installation and there is no material damage to any of the signs.
- All signs are clean from general dust build up and any other specific obscuring deposits.
- All signs are clearly visible and have not been covered up.
- All lights within 4m of internal S20 signs have been checked that the positions have not altered from design.
- All lights within 4m of internal S20 signs are in working order and clean.
- All automated lighting control systems are operational as per design.

Recommended Maintenance Checking Procedure for Ecoglo Hybrid signs:

Monthly Maintenance Check *(to be carried out by the Owner or their appointed agent)* COMPLETED

- All signs are still configured as at installation and there is no material damage to any of these products.
- All signs are clean from general dust build up and any other specific obscuring deposits.
- All signs are clearly visible and have not been covered up.
- All signs are still illuminated.

Annual Inspection *(to be carried out by an IQP)* COMPLETED

- All signs are still configured as at installation and there is no material damage to any of these products.
- All signs are clean from general dust build up and any other specific obscuring deposits.
- All signs are clearly visible and have not been covered up.
- All signs are still illuminated.

Ecoglo S20 Exit Signs Design Guide

Guide for designing systems using Ecoglo S20 photoluminescent exit signs to meet the requirements of NZBC clause F8 Signs

Introduction

Ecoglo S20 photoluminescent exit signs (S20 signs) can provide low cost, reliable, low carbon footprint, low maintenance, long life exit signage in and around buildings. Ecoglo International Ltd provides a 30 year warranty for these signs when installed indoors.

However, because S20 signs require available light to charge them sufficiently to ensure they remain code compliant, they are not suitable in all situations. In situations where S20 signs are not suitable, Ecoglo Hybrid photoluminescent exit signs (Hybrid signs) can be used.

Ecoglo Hybrid signs have a fully integrated dedicated electrical light source that ensures the photoluminescent material is always sufficiently charged. Because they do not require a battery, they require less inspection and maintenance than conventional battery-back-up electrical exit signs, and because they have fewer electrical components they can be expected to be more reliable, and last longer than conventional battery-back-up electrical exit signs.

However, Ecoglo Hybrid signs are more expensive and have a shorter life than Ecoglo S20 signs, so the best system for any specific project will use S20 signs wherever suitable, and Hybrid signs elsewhere, rather than Hybrid signs throughout.

This document provides specific design advice to show where Ecoglo S20 signs are appropriate to be installed to meet the New Zealand Building Code (NZBC) for Risk Group C buildings (as defined in NZBC Clause F6).

In locations where Ecoglo S20 signs are not appropriate, Ecoglo Hybrid signs can be used. Refer to the Ecoglo Hybrid Exit Sign Compliance Report on page 39, also available for download from www.ecoglo.co.nz.

For an overall technical justification for the use of Ecoglo S20 signs in New Zealand and a greater level of technical detail, refer to Technical Justification for Ecoglo Signs document, available for download from www.ecoglo.co.nz.

Ecoglo S20 Exit Signs Design Guide

1. Suitable spaces for S20 signs

Indoor Spaces

1) Dead-end spaces (a dead-end space does not have exit signage directing people into it) and primary access spaces (a primary access space will be occupied whenever it could be used as an escape route from another space) that will always be lit by daylight or electrical lighting when that part of the building is occupied, for example:

- classrooms
- changing rooms
- toilets
- store rooms
- plant rooms
- reception areas
- office areas
- assembly areas, gymnasiums, etc. that are not used for lights-out performances

2) Walk-through spaces (normally unoccupied), for example:

- corridors
- interconnecting lobbies
- cloakrooms
- stairwells

Walk-through spaces that are normally unoccupied **must** have light switching controls to ensure whenever the building is occupied, the spaces will be sufficiently lit with daylight and/or the supplied lighting.

See the drawings in Appendix 2 for examples of dead end spaces, primary access spaces and walk through spaces.

Suitable light switching controls include:

- Lighting is switched on whenever the building's security alarm system is de-activated. It would seem reasonable to consider this to be deemed equivalent to '5 minutes before occupation' in many circumstances;
- Lighting is switched on by a conservatively-programmed timer;
- A master switch is turned on by the first occupier that turns on all the required lighting;
- Lighting is switched on manually (only suitable for staff-only areas - staff induction requires first occupier to switch on lighting, and clear instruction signs are permanently located by all relevant light switches. (See Appendix 1).

Individual lights may have daylight sensing switching so they do not activate when there is sufficient natural light available.

Outdoor spaces

Outdoor daylight provides much greater charging of Ecoglo signs than building interiors, so that electric lighting is not normally needed to charge up Ecoglo exit signs installed outside of built structures. This includes locations that are up to 4m inside a roof overhang.

When an S20 sign is installed outdoors, and needs to be visible 24/7, it is suitable for a viewing distance 50% (half) of its rated maximum viewing distance.

If the sign does not need to be seen 24/7, it can be used at its full rated maximum viewing distance for a period of 7 hours after sunset.

[See Section 3.3 of the Technical Justification for Ecoglo Signs document (Technical Justification Alternative Solution for Ecoglo Photoluminescent Exit Signs) available for download from www.ecoglo.co.nz]

Therefore, with due regard for the appropriate viewing distances, Ecoglo S20 signage can be specified and installed outside without the need for electrical lighting to provide charging.

Note that 'outdoor coated' Ecoglo S20 signs are to be used in outdoor spaces. The coating is designed to protect the sign's print from fading and deteriorating in outdoor conditions (the photoluminescent material is naturally robust in outdoor conditions).

2. How much light is required on signs installed indoors?

Use the following table to determine how much light is required, and whether it needs to be switched on prior to occupation.

How much natural light through windows or skylights is on the face of the sign?	Is lighting in the space turned on prior to occupation?	How much light (with a colour temperature of 4000K or greater) is required on the face of the sign from the installed lighting? ³
55 lux for at least 6 hours a day	No	55 lux ^{1,2}
20 lux for at least 6 hours a day	No	100 lux ^{1,2}
20 lux for at least 6 hours a day	Yes – 5 minutes before occupation	55 lux ^{1,2}
Less than 20 lux	No	200 lux ¹
Less than 20 lux	Yes – 5 minutes before occupation	100 lux
Less than 20 lux	Yes – 10 minutes before occupation	55 lux

Notes:

1. The space that the exit sign serves must have an evacuation time no more than 10 minutes. Most 1-2 storey buildings in NZ will have evacuation times less than 10 minutes (see Appendix 3).
2. The installed lighting does not need to be switched on if natural light provides the same lux.
3. See Appendix 3 of the Technical Justification document for Ecoglo Signs available for download from www.ecoglo.co.nz for detailed justification of the required light levels.

3. How can the designer ensure the lighting is sufficient and suitable for signs inside buildings?

By confirming the following:

- 1) The Dedicated Light Source* for the S20 signs inside the building consists of the installed electrical luminaires that are within 4m of each S20 sign.
- 2) The colour temperature of each Dedicated Light Source is 4000K or greater.
- 3) The illuminance from each Dedicated Light Source is sufficient:
 - This has been checked using a lighting model for the building; or
 - This has been checked using onsite measurements; or
 - This has been checked based on comparison with similar designs such as those shown in Appendices 3 and 4.

*Dedicated Light Source: means a new or existing designated light source or designated group of light sources that are assigned to charge one or more Photoluminescent Exit Signs when natural daylight is below the Charging Illuminance Level (as defined in Photoluminescent Lighting Council Standard PLCS101 Photoluminescent Exit Signs, Part A: Definitions)

If the lighting is sufficient and suitable, and the space is suitable, Ecoglo S20 signs can be specified because they meet the requirements of NZBC Clause F8. See appendix 4 for example lighting models in daylight, and Appendix 5 for example lighting models with electric lighting.

Ecoglo S20 Exit Signs Design Guide

4. Recommended Compliance Schedule Information

Specified System SS15/4 Exit Signs

[only required if any of specified systems 1-6, 9, or 13 are required in the building]

System Description

Photoluminescent exit signage

Make

Ecoglo

Product Code and Quantity

See drawing(s) titled "XXXX", attached.

Location

To identify escape routes as per the Fire Report

Relevant Performance Standard

NZBC Clause F8.3.1 and F8.3.3 as they relate to exit signage.

Relevant Inspection and Maintenance Standard

Photoluminescent Lighting Council Standard PLCS101
Photoluminescent Exit Signs, Part C: Inspection and Maintenance.
The relevant requirements are detailed below.

Inspection and Maintenance Procedures

Planned preventative maintenance and responsive maintenance should be carried out in accordance with the corresponding table below to ensure signs remain correctly positioned and legible.

Monthly:

Inspect the system, and carry out any maintenance necessary to confirm each statement in the corresponding table.

Annually:

Inspect the system, to confirm each statement in the corresponding table.

Immediate Corrective Action

Signs shall be replaced before they become illegible, and shall be replaced immediately should they be missing. Defects in illuminated signs shall be fixed immediately as they are apparent.

Reporting procedure

All inspection and maintenance records of the above work are to be held on site in a durable, hard-bound log book, and are to be available to any authorised inspection agency.

Responsibilities

Monthly inspections and maintenance are to be carried out by the owner or their appointed agent. Annual inspections are to be carried out by an Independent Qualified Person. Inspection and maintenance records are to be maintained by the owner or their appointed agent.

Action	Complete
All signs are still configured as at installation and there is no material damage to any of these products.	
All signs are clean from general dust build up and any other specific obscuring deposits.	
All signs are clearly visible and have not been covered up.	
All lights within 4m of internal Ecoglo S20 exit signs have been checked that the positions have not altered from design.	
All lights within 4m of internal Ecoglo S20 exit signs are in working order and clean.	
All light switching control systems are operational as per design. (Specify the light switching control systems)	

Appendix 1

Example of Instruction Sign to be placed by Light Switch

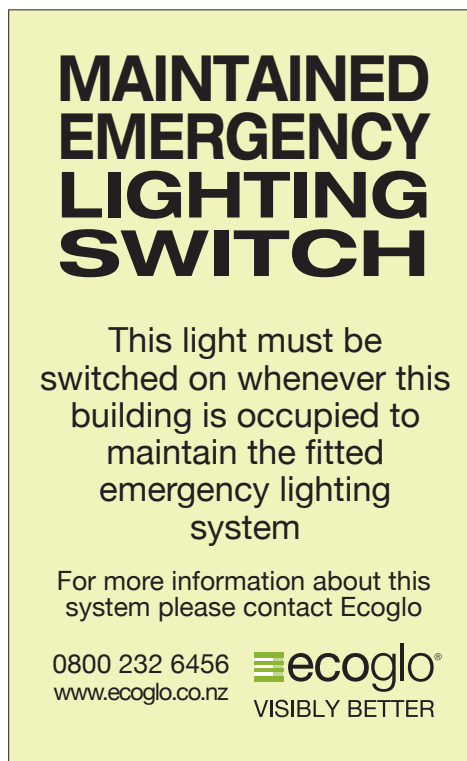

Appendix 2

Examples of dead-end spaces, walk through spaces and primary access spaces



Fig. 1.

Typical small scale medical office. The corridor is not normally occupied.

- Dead end space
- Walk through space
- Primary access space

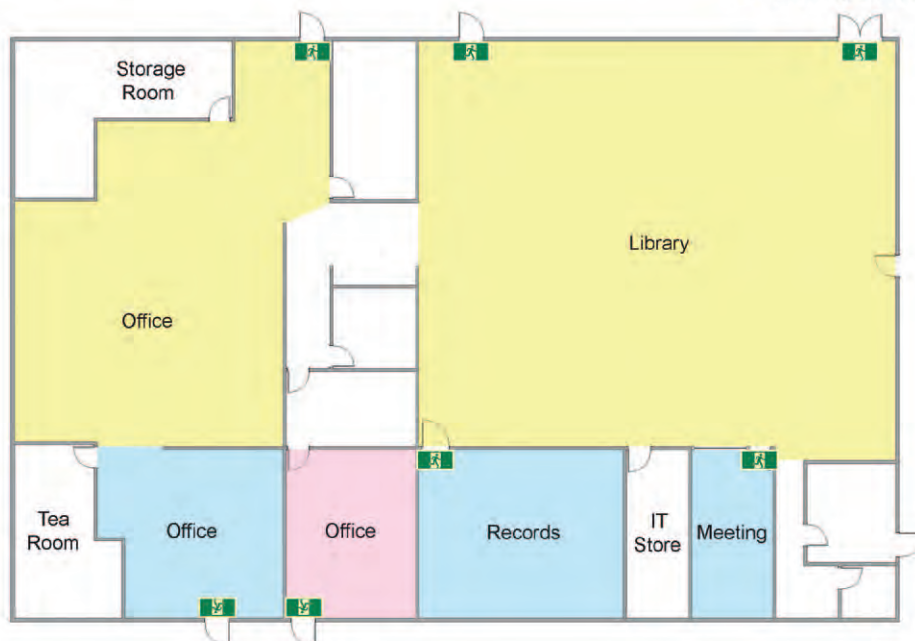

Fig. 2.

School Library and Admin area. The pink office space may not be occupied when used as an escape route from the adjoining office space.

- Dead end space
- Walk through space
- Primary access space

Appendix 2 (cont.)



Fig. 3a.

Typical early childcare centre. Some exit signs are in spaces that are not always occupied.

- Dead end space
- Walk through space
- Primary access space

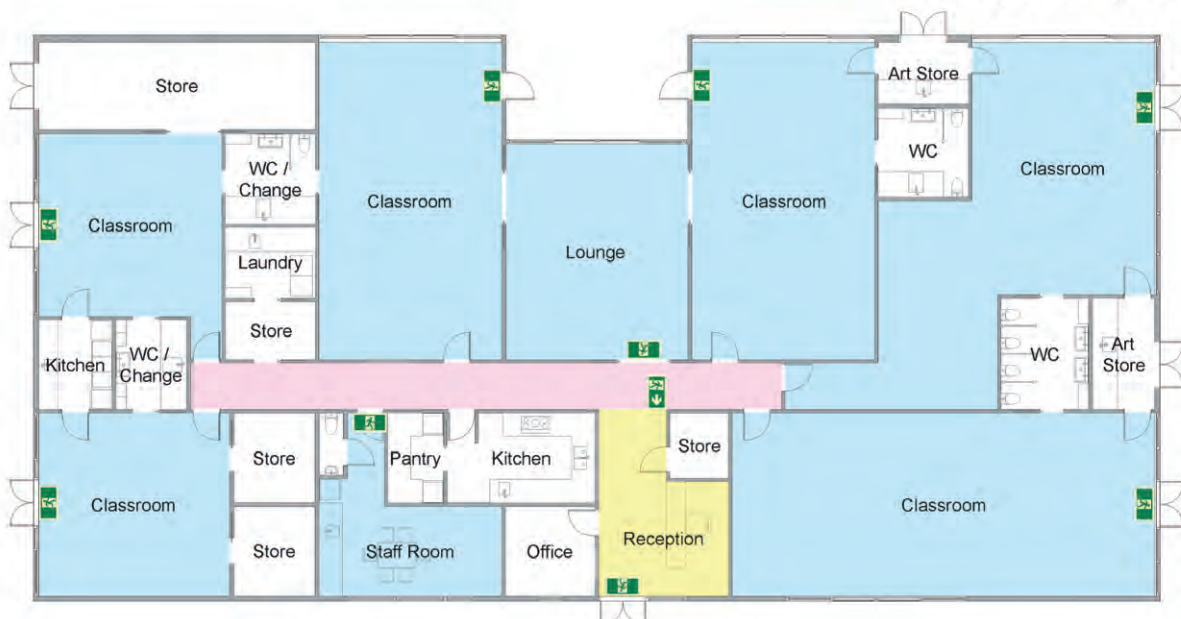

Fig. 3b.

Same building as 3a. above, but used for after school activities.

- Dead end space
- Walk through space
- Primary access space

Appendix 2 (cont.)



Fig. 4a.

A warehouse building where the escape route passes through a normally unoccupied space.



Fig. 4b.

A warehouse building where the escape route from the main warehouse area is not through an unoccupied space

Appendix 2 (cont.)



Fig. 5a.
School Block

- Dead end space
- Walk through space
- Primary access space



Fig. 5b.
School Block where the escape routes are through adjacent classrooms that may not be occupied.

- Dead end space
- Walk through space
- Primary access space

Appendix 3

Evacuation Time Examples

Refer to the New Zealand Building Code Clause C/MM2 for further details and explanations of terms used here.

RSET can be calculated in accordance with Clause C/MM2, using values of zero for T_d and T_n , since occupants will be immediately aware of a black-out requiring evacuation. For photoluminescent exit signage, the relevant 'evacuation time' is the time between when the lighting fails (requiring the photoluminescent properties of the sign to provide adequate identification of the escape route) and the occupant leaves the space that the exit sign serves. Looking at table 3.3 in C/MM2, a conservative pre-travel activity time would be 60 seconds.

A conservative travel speed can be taken as 1m/second, (including stairways no steeper than 180mm riser, 280mm tread), and a conservative flow rate at a doorway is 50 people per minute per door leaf. An escape route serving up to 100 people through single leaf door sets and up to 120 metres long would have an evacuation time of 3 minutes. An assembly space with capacity for 450 people will require 3.2m of exit door width (which could be two double doors), so if one of these is unusable the evacuation time would be about 5 minutes. If the space had three double doors, the evacuation time with one of these unusable would be 3-4 minutes. This indicates that an evacuation time of less than 10 minutes is realistic in many Risk Group C buildings.

Appendix 4

Lighting Models - daylight



Room layout used for natural lighting model (electric lights turned off)

Ecoglo S20 Exit Signs Design Guide

Appendix 4 (Cont.)



View 1. 65 lux illuminance on the sign for a min. of 6 hours per day from natural light.



View 2. 40 lux illuminance on the sign for a min. of 6 hours per day from natural light.

Appendix 4 (Cont.)

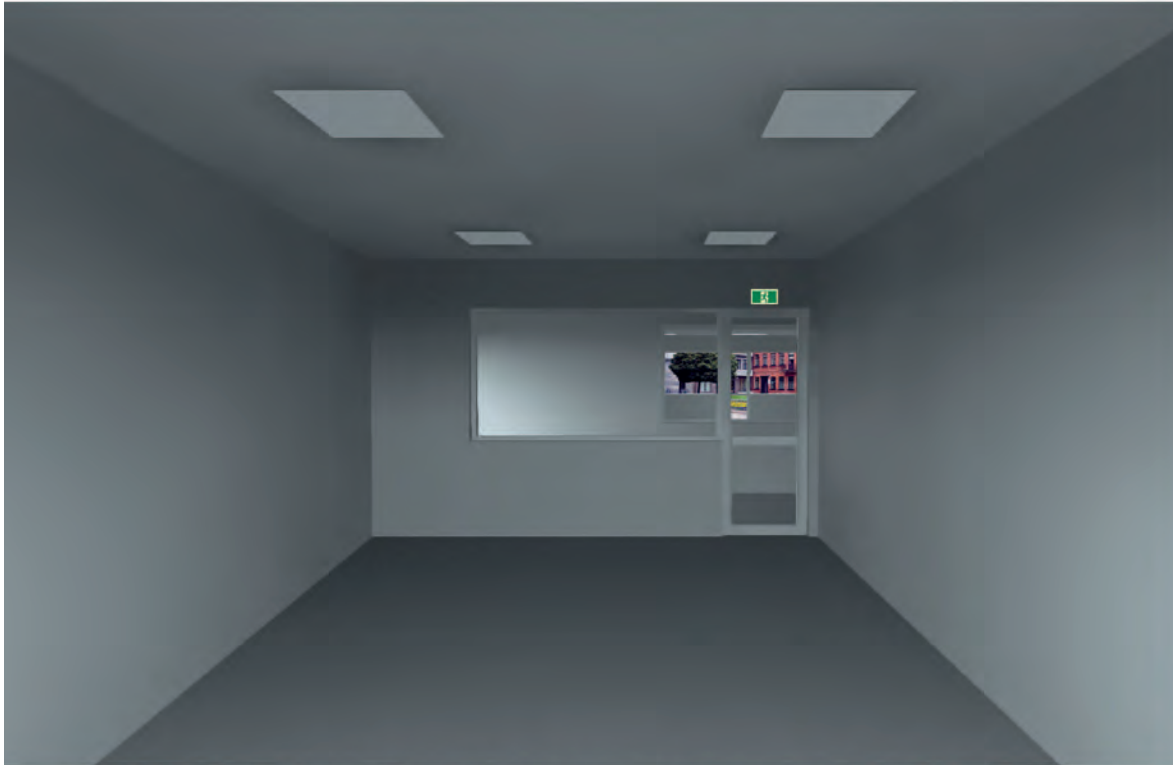

View 3. 25 lux illuminance on the sign for a min. of 6 hours per day from natural light.



View 4. 30 lux illuminance on the sign for a min. of 6 hours per day from natural light.

Appendix 4 (Cont.)



View 5. 5 lux illuminance on the sign for a min. of 6 hours per day from natural light.



View 6. 20 lux illuminance on the sign for a min. of 6 hours per day from natural light.

Appendix 5

Lighting Models - electric lighting

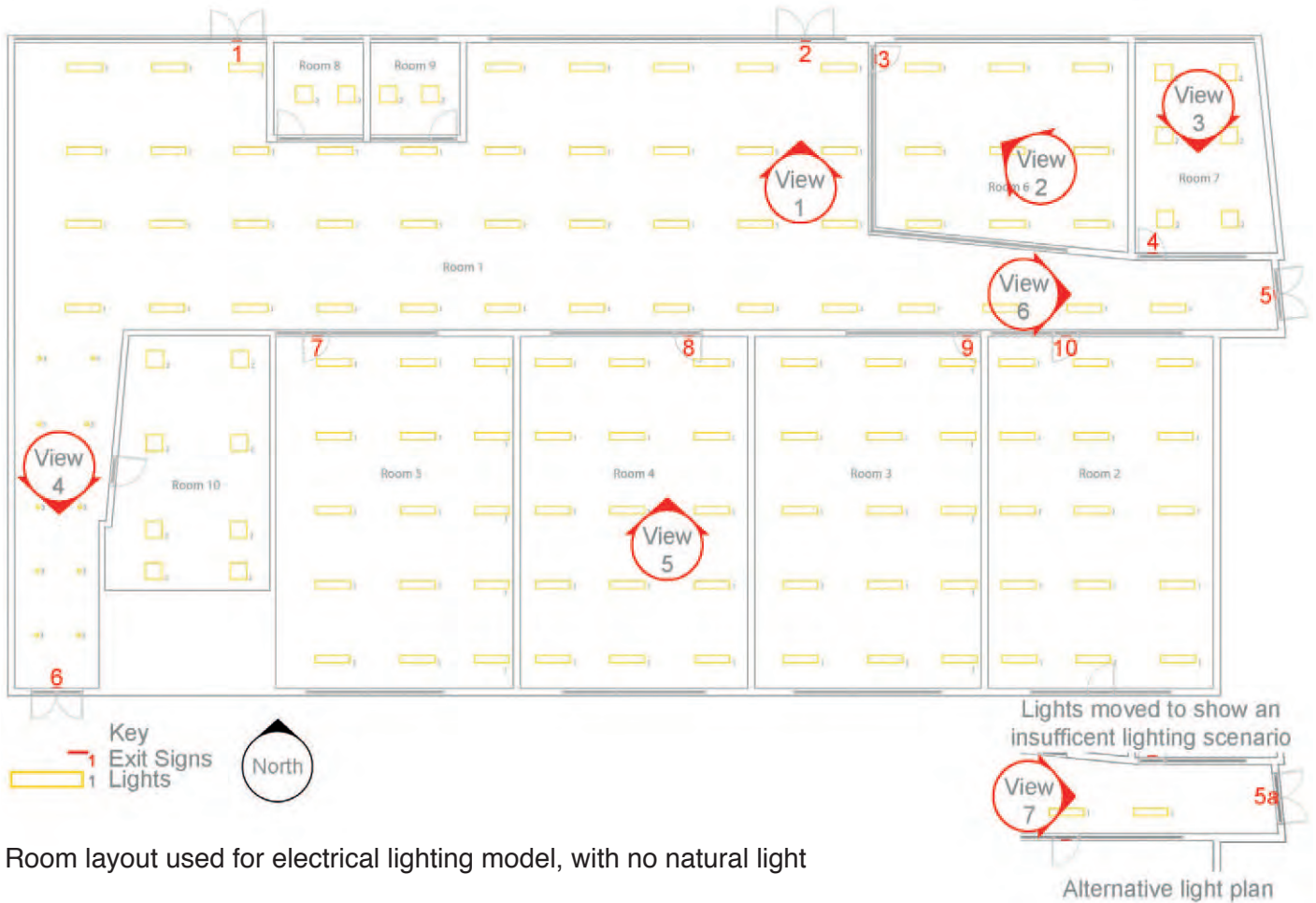

Room layout used for electrical lighting model, with no natural light

Ecoglo S20 Exit Signs Design Guide

Appendix 5 (Cont.)



View 1. 167 lux illuminance on the sign from electric lighting.



View 2. 136 lux illuminance on the sign from electric lighting.

Appendix 5 (Cont.)



View 3. 214 lux illuminance on the sign from electric lighting.



View 4. 98 lux illuminance on the sign from electric lighting.

Ecoglo S20 Exit Signs Design Guide

Appendix 5 (Cont.)



View 5. 258 lux illuminance on the sign from electric lighting.



View 6. 65 lux illuminance on the sign from electric lighting.

Appendix 5 (Cont.)



View 7. 50 lux illuminance on the sign from electric lighting. Insufficient lighting scenario.

Appendix 5 (Cont.)

Lighting model details

Luminaire Parts List								
	Manufacturer	Luminaire type	Item number	Fitting	Luminous flux	Light loss factor	Connected load	Quantity
1	Versalux Pty Ltd	ASTI series Opal LED panel luminaire	ATP.L140.480.22-800	1x	3223 lm	0.80	32W	112
2	Versalux Pty Ltd	ASTI series Opalescent LED panel luminaire 800mA driver setting	ATP.M140.480.22-800	1x	3175 lm	0.80	32W	18
3	Nimbus Lighting Group	Aesthetics Lighting Turama LED Downlight	TM3598P/40/A9 37-FG/01	1x	2690 lm	0.80	34.9W	10

Measured illuminance values on the face of the signs in the lighting model

Name	Illuminance on the sign from electric lighting	Illuminance from daylight (for a minimum of 6 hours per day throughout the year)
Exit sign 1	314 lx	65 lx
Exit sign 2	167 lx	65 lx
Exit sign 3	136 lx	40 lx
Exit sign 4	214 lx	25 lx
Exit sign 5	65 lx	20 lx
Exit sign 5a	50 lx	20 lx
Exit sign 6	98 lx	30 lx
Exit sign 7	272 lx	10 lx
Exit sign 8	258 lx	5 lx
Exit sign 9	416 lx	5 lx
Exit sign 10	250 lx	5 lx

Dialux model uses	70% Ceiling reflectance
	50% Wall reflectance
	20% Floor reflectance

Lighting has been designed to meet Ministry of Education requirements

Compliance with NZBC F8/AS1

Ecoglo HYU hybrid exit signs are photoluminescent exit signs that are charged with an integrated light source. The light source ensures the signs are sufficiently charged at all times to meet the requirements of the New Zealand Building Code (NZBC) Clause F8/AS1.

The following information provides a technical explanation of how Ecoglo hybrid signs comply with NZBC F8/AS1.

As with Ecoglo S20 photoluminescent exit signs (S20 signs), the physical format of Ecoglo HYU hybrid photoluminescent exit signs (hybrid signs) meets all the relevant requirements of F8/AS1. Where hybrid signs differ from S20 signs is in the way the signs are charged.

1. NZBC F8/AS1 Requirements

The relevant paragraph of NZBC Clause F8/AS1 is detailed below:

4.5.4 Photoluminescent signs

Photoluminescent signs shall, in the event of a power failure, continue to provide a **minimum luminance of 30 mcd/m² for the duration** prescribed in NZBC Clause F6 whenever the building is occupied. Photoluminescent signs **shall be maintained in a charged state** such that in the event of an emergency when the building is occupied, the exit signs will be at full operational charge and will continue to operate at the prescribed level and for the prescribed time (refer to NZBC Clause F6). **Illumination for charging** the photoluminescent signage **shall be not less than 100 lux** and suitable for charging photoluminescent material.

Key terms in F8/AS1 4.5.4

“Minimum luminance of 30mcd/m² for the duration...”

Luminance:

NZBC Clause F6 requires luminance at 30mcd/m² for a minimum period of:

Duration:

30 minutes duration for Risk Group C buildings; and
90 minutes duration for Risk Group B buildings.

Ecoglo runs an in-house luminance test facility, which is validated by comparative testing with independent test laboratories. The in-house test facility enables the efficient testing of a wide range of photoluminescent materials. Ecoglo has carried out over 3000 in-house tests since 2003.

The data below is extracted from Ecoglo records for the following in house test:

Test ID	Date	Test Sample	Charging Lamp Type	Illuminance on Sample	Charging Time
H063	11 May 2017	HYU1-RM	Integral LEDs	N/A	60 minutes

F6 Risk Group C buildings:

The test results revealed that the luminance at 30 minutes is 290mcd/m², clearly well above the 30mcd/m² required. At this level, even if the integrated light source were to lose as much as 50% of its initial brightness during its lifetime, there would still be sufficient luminance.

F6 Risk Group B buildings:

The test results revealed that the luminance at 90 minutes is 87mcd/m², clearly well above the 30mcd/m² required. At this level, even if the integrated light source were to lose as much as 50% of its initial brightness during its lifetime, there would still be sufficient luminance.

Signs “shall be maintained in a charged state...”

During installation hybrid signs are connected to a permanent electrical supply to ensure that they will be maintained in a charged state. A suitably qualified electrical tradesperson is required to connect the signs to circuit supplying general lighting in the area concerned. Circuit breakers for the relevant lighting circuits shall be labelled “Emergency Lighting Supply – Do not isolate”.

Charging illumination

“shall be not less than 100 lux...”

Ecoglo has recorded in-house measurements to confirm the charging illumination. The luminance of Ecoglo hybrid signs when connected to an electrical supply is 150cd/m².

Ecoglo photoluminescent material is typically 70% reflective during charging/charged states, so using the following formula:

$$Illuminance (lux) = Luminance (cd/m^2) \times \pi / reflectivity$$

the charging illumination is shown to be $150 \times \pi / 70\% = 670 \text{ lux}$.

The result is clearly well above the required 100 lux. At this level, even if the integrated light source were to lose 50% of its initial brightness during its lifetime, there would still be sufficient charging illumination.

2. Compliance with Other Relevant Standards

Compliance with AS 2293 Standards

The AS 2293 standards do not cover photoluminescent exit signs, and are therefore not applicable to Ecoglo hybrid exit signs.

Electrical Safety Testing

The Ecoglo Supplier Declaration of Conformance confirms that Ecoglo hybrid signs comply with the relevant standards:

AS/NZS 60598.1 Luminaires Part 1: General Requirements and Tests; and AS/NZS IEC 61347 Lamp Controlgear Part 1 and Part 2.13.

Electromagnetic Compatibility Testing

The Ecoglo Supplier Declaration of Conformance confirms that Ecoglo hybrid signs comply with the relevant standard:

AS/NZS CISPR 15 Limits and Methods of Measurement of Radio Disturbance Characteristics of Electrical Lighting and Similar Equipment.

3. Ongoing Inspection and Maintenance

The Ecoglo document *“Technical Justification for Ecoglo Signs (available under Technical at www.ecoglo.co.nz)”* shows that ongoing verification of the performance of Ecoglo photoluminescent material is not necessary. ‘Discharge testing’ as specified in AS/NZS 2293.2 is required for battery back-up electrical exit sign systems because these systems have a relatively high frequency of fault/failure for a life safety building component. Ecoglo hybrid signs are intrinsically fail-safe and are electronically much simpler than battery back-up exit signs.

The photoluminescent material will continue to provide useful glow for many hours after failure of the main lighting system, and requires no more than 5 minutes recharge after an extended loss of power to be fully operational again. It also still works as a standard photoluminescent exit sign even if the integrated light source fails.

Nonetheless, hybrid signs do have electrical components, and all electrical components are subject to failure. Therefore, regular inspection is warranted to ensure that the integrated charging light is still operating.

The following specified system information, and inspection and maintenance procedures are appropriate to the reasonably expected frequency of fault/failure of Ecoglo hybrid signs. They are recommended to be part of the Compliance Schedule for the building:

4. Specified System SS15/4 Exit Signs

(only required if any of Specified Systems 1-6, 9, or 13 are required in the building)

System Description

Photoluminescent exit signage.

Make

Ecoglo

Product Code and Quantity

See drawing(s) titled “XXXX”, attached.

Location

To identify escape routes as per the Fire Report.

Relevant Performance Standard

NZBC Clause F8.3.1 and F8.3.3 as they relate to exit signage.

Relevant Inspection and Maintenance Standard

Photoluminescent Lighting Council Standard PLCS101 Photoluminescent Exit Signs, Part C: Inspection and Maintenance. The relevant requirements are detailed below.

Inspection and Maintenance Procedures

Planned preventative maintenance and responsive maintenance should be carried out in accordance with the corresponding table below to ensure signs remain correctly positioned and legible.

Action	Complete
All signs are still configured as at installation and there is no material damage to any of these products.	
All signs are clean from general dust build up and any other specific obscuring deposits.	
All signs are clearly visible and have not been covered up.	
All Ecoglo hybrid signs are still illuminated.	

Monthly:

Inspect the system, and carry out any maintenance necessary to confirm each statement in the table.

Annually:

Inspect the system, to confirm each statement in the table.

Immediate Corrective Action

Signs shall be replaced before they become illegible, and shall be replaced immediately should they be missing.

Defects in illuminated signs shall be fixed immediately as they are apparent.

Reporting Procedure

All inspection and maintenance records of the above work are to be held on site in a durable, hard-bound log book, and are to be available to any authorised inspection agency.

Responsibilities

Monthly inspections and maintenance are to be carried out by the owner or their appointed agent.

Annual inspection is to be carried out by an Independent Qualified Person.

Inspection and maintenance records are to be maintained by the owner or their appointed agent.

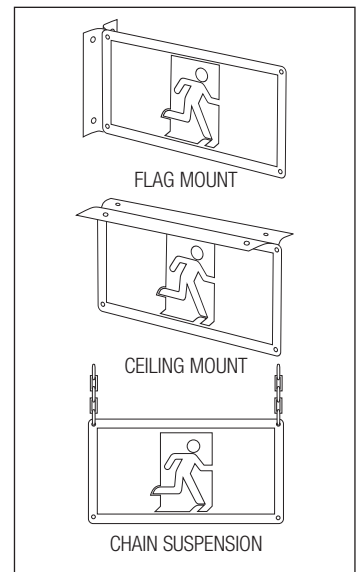

Ecoglo "Exit" S20 Signs are designed to be used in and about buildings to identify escape routes to meet NZBC Clause F8 "Signs". The signs will be clearly visible and readily understandable under all conditions of foreseeable use, including emergency conditions.

SIGN DEFINITION

Exit straight on from here.

COMPLIANCE

Ecoglo "Exit" S20 signs can be used to meet F8/AS1, as detailed below, or can be used in alternative solutions.

Phone Ecoglo or email Engineer@ecoglo.com for design advice for alternative solutions.

PERFORMANCE

Risk Group C Building

30 minutes visibility

Minimum charging illuminance of 100 lux continuously during occupancy will ensure minimum luminance of 30 mcd for 30 minutes after failure of the main lighting.

Risk Group B Building

90 minutes visibility

Minimum charging illuminance of 350 lux continuously during occupancy will ensure minimum luminance of 30 mcd for 90 minutes after failure of the main lighting.

UV Resistance - Loss of luminance after 1000 hrs ASTM G-155
Cycle 1 exposure: <10%: Pass

Salt Spray Resistance - ASTM B117: Pass

Washability - ASTM D4828: Pass

Rate of Burning - ASTM D635: Pass

Surface Flammability - ASTM E162: Pass

Toxicity - Bombardier Toxic Gas Generation Test SMP800-C: Pass

Radioactivity - ASTM D3648: Pass

SUPPLY

The sign is available in 2 sizes - maximum viewing distance 16 metres and maximum viewing distance 24 metres.

PRODUCT CODE	PRODUCT NAME	SIGN DEFINITION	SIGN SIZE	MAXIMUM VIEWING DISTANCE
S20-EX2313-16m	Exit	Exit straight on from here	230mm x 133mm	16 metres
S20-EX2916-24m	Exit	Exit straight on from here	290mm x 162mm	24 metres

COMPOSITION

The high visibility flat panel is manufactured from 5005 0.9mm aluminium sheet. Custom made photoluminescent pigments are embedded in thermoset polyester carriers to integrally bond the active ingredients onto the aluminium sheet following curing at high temperature.

INSTALLATION

The standard sign is supplied with fixers for mounting flat on a wall.

Signs with brackets for ceiling or flag mounting are available - see order codes for signs and brackets below.

Mounting brackets take one sign or two signs back to back.

PRODUCT CODE	PRODUCT NAME	CEILING MOUNT BRACKET	FLAG MOUNT BRACKET
S20-EX2313-16m	Exit	BR1-230	BR1-133
S20-EX2916-24m	Exit	BR1-290	BR1-162

Chain suspension is also available.



SIGN FLAT ON WALL

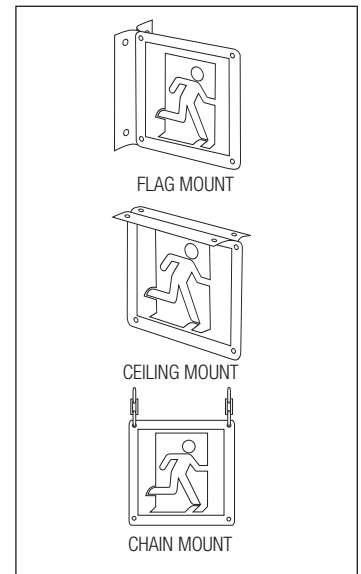

Ecoglo "Pictogram Uni" S20 Signs are designed to be used in and about buildings to identify escape routes to meet NZBC Clause F8 "Signs". The signs will be clearly visible and readily understandable under all conditions of foreseeable use, including emergency conditions.

SIGN DEFINITION

Exit straight on from here.

COMPLIANCE

Ecoglo "Pictogram Uni" S20 signs can be used to meet F8/AS1, as detailed below, or can be used in alternative solutions. Phone Ecoglo or email Engineer@ecoglo.com for design advice for alternative solutions.

PERFORMANCE

Risk Group C Building

30 minutes visibility
Minimum charging illuminance of 100 lux continuously during occupancy will ensure minimum luminance of 30 mcd for 30 minutes after failure of the main lighting.

Risk Group B Building

90 minutes visibility
Minimum charging illuminance of 350 lux continuously during occupancy will ensure minimum luminance of 30 mcd for 90 minutes after failure of the main lighting.

UV Resistance - Loss of luminance after 1000 hrs ASTM G-155 Cycle 1 exposure: <10%: Pass

Salt Spray Resistance - ASTM B117: Pass

Washability - ASTM D4828: Pass

Rate of Burning - ASTM D635: Pass

Surface Flammability - ASTM E162: Pass

Toxicity - Bombardier Toxic Gas Generation Test SMP800-C: Pass
Radioactivity - ASTM D3648: Pass

SUPPLY

The sign is available in 2 sizes - maximum viewing distance 16 metres and maximum viewing distance 24 metres.

PRODUCT CODE	PRODUCT NAME	SIGN DEFINITION	SIGN SIZE	MAXIMUM VIEWING DISTANCE
S20-RM1616UN-16m	Pictogram Uni	Exit straight on from here	162mm x 162mm	16 metres
S20-RM2323UN-24m	Pictogram Uni	Exit straight on from here	230mm x 230mm	24 metres

COMPOSITION

The high visibility flat panel is manufactured from 5005 0.9mm aluminium sheet. Custom made photoluminescent pigments are embedded in thermoset polyester carriers to integrally bond the active ingredients onto the aluminium sheet following curing at high temperature.

INSTALLATION

The standard sign is supplied with fixers for mounting flat on a wall. *Signs with brackets for ceiling or flag mounting are available - see order codes for signs and brackets below.*

PRODUCT CODE	PRODUCT NAME	CEILING MOUNT BRACKET	FLAG MOUNT BRACKET
S20-RM1616UN-16m	Pictogram Uni	BR1-162	BR1-162
S20-RM2323UN-24m	Pictogram Uni	BR1-230	BR1-230

Chain suspension is also available.

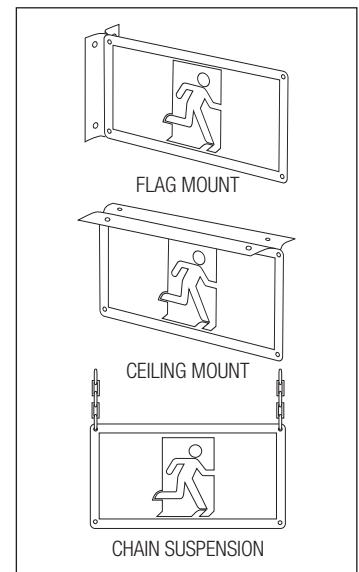

Ecoglo "Pictogram" S20 Signs are designed to be used in and about buildings to identify escape routes to meet NZBC Clause F8 "Signs". The signs will be clearly visible and readily understandable under all conditions of foreseeable use, including emergency conditions.

SIGN DEFINITION

Exit straight on from here.

COMPLIANCE

Ecoglo "Pictogram" S20 signs can be used to meet F8/AS1, as detailed below, or can be used in alternative solutions. Phone Ecoglo or email Engineer@ecoglo.com for design advice for alternative solutions.

PERFORMANCE

Risk Group C Building

30 minutes visibility

Minimum charging illuminance of 100 lux continuously during occupancy will ensure minimum luminance of 30 mcd for 30 minutes after failure of the main lighting.

Risk Group B Building

90 minutes visibility

Minimum charging illuminance of 350 lux continuously during occupancy will ensure minimum luminance of 30 mcd for 90 minutes after failure of the main lighting.

UV Resistance - Loss of luminance after 1000 hrs ASTM G-155 Cycle 1 exposure: <10%: Pass

Salt Spray Resistance - ASTM B117: Pass

Washability - ASTM D4828: Pass

Rate of Burning - ASTM D635: Pass

Surface Flammability - ASTM E162: Pass

Toxicity - Bombardier Toxic Gas Generation Test SMP800-C: Pass

Radioactivity - ASTM D3648: Pass

SUPPLY

The sign is available in 2 sizes - maximum viewing distance 16 metres and maximum viewing distance 24 metres.

PRODUCT CODE	PRODUCT NAME	SIGN DEFINITION	SIGN SIZE	MAXIMUM VIEWING DISTANCE
S20-RM2916-16m	Pictogram	Exit straight on from here	290mm x 162mm	16 metres
S20-RM4223-24m	Pictogram	Exit straight on from here	420mm x 230mm	24 metres

COMPOSITION

The high visibility flat panel is manufactured from 5005 0.9mm aluminium sheet. Custom made photoluminescent pigments are embedded in thermoset polyester carriers to integrally bond the active ingredients onto the aluminium sheet following curing at high temperature.

INSTALLATION

The standard sign is supplied with fixers for mounting flat on a wall. *Signs with brackets for ceiling or flag mounting are available - see order codes for signs and brackets below.*

PRODUCT CODE	PRODUCT NAME	CEILING MOUNT BRACKET	FLAG MOUNT BRACKET
S20-RM2916-16m	Pictogram	BR1-290	BR1-162
S20-RM4223-24m	Pictogram	BR1-420	BR1-230

Chain suspension is also available.

2018 V1

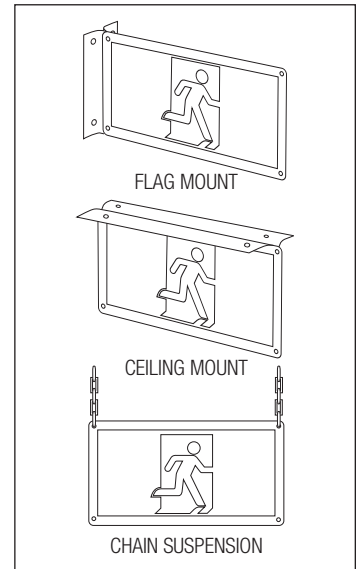

Ecoglo MADE TO ORDER “Pictogram” S20 Signs are designed for use in locations where Ecoglo standard signs are considered too small. The purpose of the signs is to identify escape routes in and about buildings to meet NZBC Clause F8 “Signs”. The signs will be clearly visible and readily understandable under all conditions of foreseeable use, including emergency conditions.

SIGN DEFINITION

Exit straight on from here.

COMPLIANCE

Ecoglo MADE TO ORDER “Pictogram” S20 signs can be used in alternative solutions to meet F8. Phone Ecoglo or email Engineer@ecoglo.com for design advice for alternative solutions.

PERFORMANCE

UV Resistance - Loss of luminance after 1000 hrs ASTM G-155 Cycle 1 exposure: <10%: Pass

Salt Spray Resistance - ASTM B117: Pass

Washability - ASTM D4828: Pass

Rate of Burning - ASTM D635: Pass

Surface Flammability - ASTM E162: Pass

Toxicity - Bombardier Toxic Gas Generation Test SMP800-C: Pass

Radioactivity - ASTM D3648: Pass

COMPOSITION

The high visibility flat panel is manufactured from 5005 0.9mm aluminium sheet. Custom made photoluminescent pigments are embedded in thermoset polyester carriers to integrally bond the active ingredients onto the aluminium sheet following curing at high temperature.

SUPPLY

The sign can be made to order by Ecoglo in 3 sizes with maximum viewing distances of 32 metres, 40 metres and 48 metres.

PRODUCT CODE	PRODUCT NAME	SIGN DEFINITION	SIGN SIZE	MAXIMUM VIEWING DISTANCE
S20-RM5630-32m	Pictogram	Exit straight on from here	560mm x 300mm	32 metres
S20-RM7038-40m	Pictogram	Exit straight on from here	700mm x 375mm	40 metres
S20-RM8445-48m	Pictogram	Exit straight on from here	840mm x 450mm	48 metres

INSTALLATION

The standard sign is supplied with fixers for mounting flat on a wall.

Signs with brackets for ceiling or flag mounting are available - see order codes for signs and brackets below.

PRODUCT CODE	PRODUCT NAME	CEILING MOUNT BRACKET	FLAG MOUNT BRACKET
S20-RM5630-32m	Pictogram	BR1-560	BR1-300
S20-RM7038-40m	Pictogram	BR1-700	BR1-375
S20-RM8445-48m	Pictogram	BR1-840	BR1-450

Chain suspension is also available.

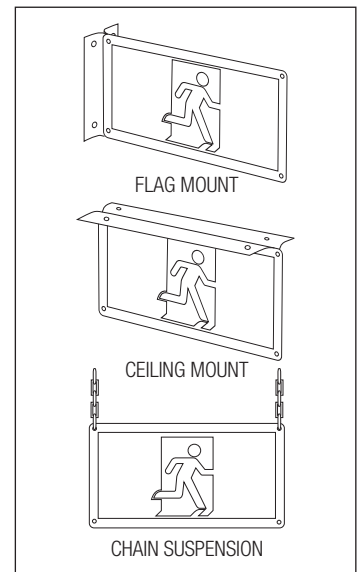

Ecoglo "Pictogram Hi Vis" S20 Signs are designed to be used in and about buildings to identify escape routes to meet NZBC Clause F8 "Signs". The signs will be clearly visible and readily understandable under all conditions of foreseeable use, including emergency conditions.

SIGN DEFINITION

Exit straight on from here.

COMPLIANCE

Ecoglo "Pictogram Hi Vis" S20 signs can be used in F8 Alternative Solutions as detailed below. Phone Ecoglo or email Engineer@ecoglo.com for design advice for alternative solutions.

PERFORMANCE

Risk Group C Building

30 minutes visibility

Minimum charging illuminance of 100 lux continuously during occupancy will ensure minimum luminance of 30 mcd for 30 minutes after failure of the main lighting.

Risk Group B Building

90 minutes visibility

Minimum charging illuminance of 350 lux continuously during occupancy will ensure minimum luminance of 30 mcd for 90 minutes after failure of the main lighting.

UV Resistance - Loss of luminance after 1000 hrs ASTM G-155

Cycle 1 exposure: <10%: Pass

Salt Spray Resistance - ASTM B117: Pass

Washability - ASTM D4828: Pass

Rate of Burning - ASTM D635: Pass

Surface Flammability - ASTM E162: Pass

Toxicity - Bombardier Toxic Gas Generation Test SMP800-C: Pass

Radioactivity - ASTM D3648: Pass

SUPPLY

The sign is available in 2 sizes - maximum viewing distance 16 metres and maximum viewing distance 24 metres.

PRODUCT CODE	PRODUCT NAME	SIGN DEFINITION	SIGN SIZE	MAXIMUM VIEWING DISTANCE
S20-RM2916HV-16m	Pictogram Hi Vis	Exit straight on from here	290mm x 162mm	16 metres
S20-RM4223HV-24m	Pictogram Hi Vis	Exit straight on from here	420mm x 230mm	24 metres

COMPOSITION

The high visibility flat panel is manufactured from 5005 0.9mm aluminium sheet. Custom made photoluminescent pigments are embedded in thermoset polyester carriers to integrally bond the active ingredients onto the aluminium sheet following curing at high temperature.

INSTALLATION

The standard sign is supplied with fixers for mounting flat on a wall. Signs with brackets for ceiling or flag mounting are available - see order codes for signs and brackets below.

Mounting brackets take one sign or two signs back to back.

PRODUCT CODE	PRODUCT NAME	CEILING MOUNT BRACKET	FLAG MOUNT BRACKET
S20-RM2916HV-16m	Pictogram Hi Vis	BR1-290	BR1-162
S20-RM4223HV-24m	Pictogram Hi Vis	BR1-420	BR1-230

Chain suspension is also available.

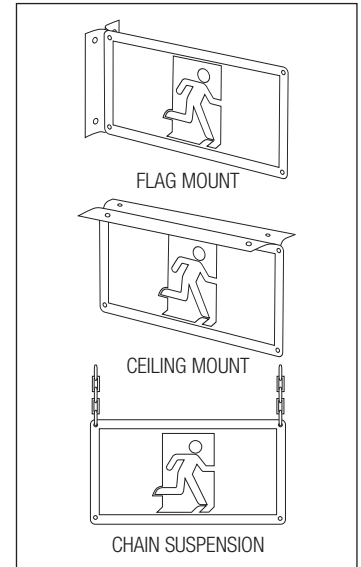
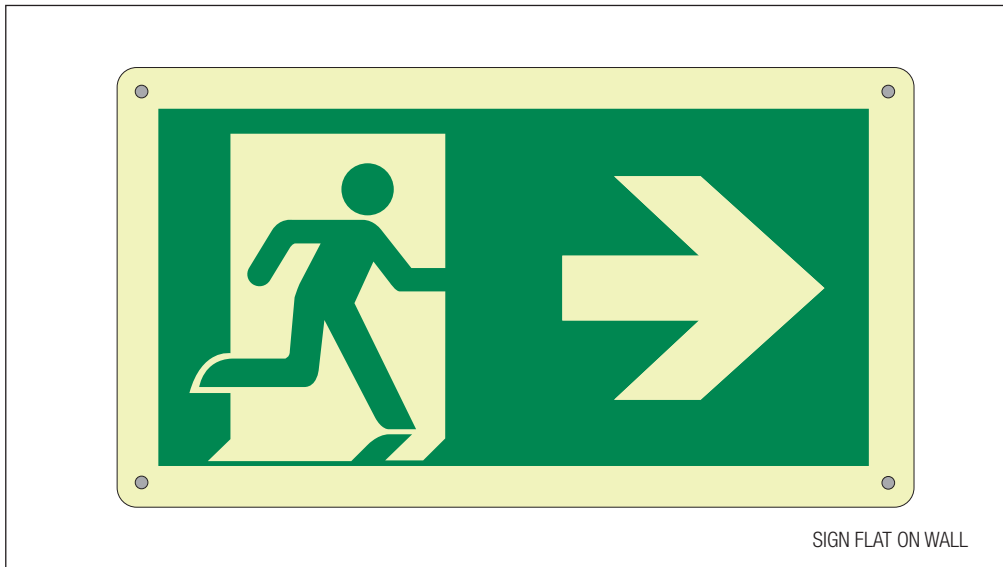

Ecoglo "Pictogram Right" S20 Signs are designed to be used in and about buildings to identify escape routes to meet NZBC Clause F8 "Signs". The signs will be clearly visible and readily understandable under all conditions of foreseeable use, including emergency conditions.

SIGN DEFINITION

Exit right from here.

COMPLIANCE

Ecoglo "Pictogram Right" S20 signs can be used to meet F8/AS1, as detailed below, or can be used in alternative solutions. Phone Ecoglo or email Engineer@ecoglo.com for design advice for alternative solutions.

PERFORMANCE

Risk Group C Building

30 minutes visibility

Minimum charging illuminance of 100 lux continuously during occupancy will ensure minimum luminance of 30 mcd for 30 minutes after failure of the main lighting.

Risk Group B Building

90 minutes visibility

Minimum charging illuminance of 350 lux continuously during occupancy will ensure minimum luminance of 30 mcd for 90 minutes after failure of the main lighting.

UV Resistance - Loss of luminance after 1000 hrs ASTM G-155 Cycle 1 exposure: <10%: Pass

Salt Spray Resistance - ASTM B117: Pass

Washability - ASTM D4828: Pass

Rate of Burning - ASTM D635: Pass

Surface Flammability - ASTM E162: Pass

Toxicity - Bombardier Toxic Gas Generation Test SMP800-C: Pass

Radioactivity - ASTM D3648: Pass

SUPPLY

The sign is available in 2 sizes - maximum viewing distance 16 metres and maximum viewing distance 24 metres. Double sided versions are also available in the 2 sizes.

PRODUCT CODE	PRODUCT NAME	SIGN DEFINITION	SIGN SIZE	MAXIMUM VIEWING DISTANCE
S20-RMR2916-16m	Pictogram Right	Exit right from here	290mm x 162mm	16 metres
S20-RMR4223-24m	Pictogram Right	Exit right from here	420mm x 230mm	24 metres
DSS20-RMD2916-16m	Pictogram Double Sided	Exit right or left from intersection	290mm x 162mm	16 metres
DSS20-RMD4223-24m	Pictogram Double Sided	Exit right or left from intersection	420mm x 230mm	24 metres

COMPOSITION

The high visibility flat panel is manufactured from 5005 0-9mm aluminium sheet. Custom made photoluminescent pigments are embedded in thermoset polyester carriers to integrally bond the active ingredients onto the aluminium sheet following curing at high temperature.

INSTALLATION

The standard sign is supplied with fixers for mounting flat on a wall.

Signs with brackets for ceiling or flag mounting are available - see order codes for signs and brackets below.

Mounting brackets take one sign or two signs back to back.

PRODUCT CODE	PRODUCT NAME	CEILING MOUNT BRACKET	FLAG MOUNT BRACKET
S20-RMR2916-16m	Pictogram Right	BR1-290	BR1-162
S20-RMR4223-24m	Pictogram Right	BR1-420	BR1-230
DSS20-RMD2916-16m	Pictogram Double Sided	BR1-290	BR1-162
DSS20-RMD4223-24m	Pictogram Double Sided	BR1-420	BR1-230

Chain suspension is also available.

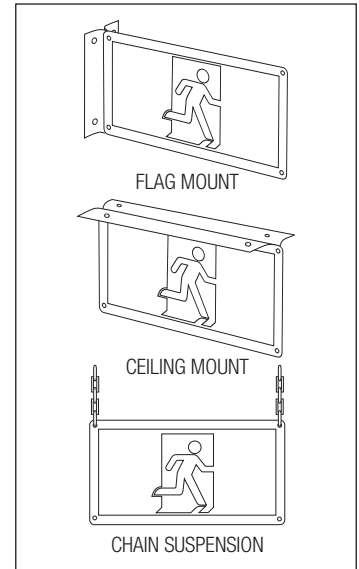

Ecoglo MADE TO ORDER “Pictogram Right” S20 Signs are designed for use in locations where Ecoglo standard signs are considered too small. The purpose of the signs is to identify escape routes in and about buildings to meet NZBC Clause F8 “Signs”. The signs will be clearly visible and readily understandable under all conditions of foreseeable use, including emergency conditions.

SIGN DEFINITION

Exit right from here.

COMPLIANCE

Ecoglo MADE TO ORDER “Pictogram Right” S20 signs can be used in alternative solutions to meet F8. Phone Ecoglo or email Engineer@ecoglo.com for design advice for alternative solutions.

PERFORMANCE

UV Resistance - Loss of luminance after 1000 hrs ASTM G-155 Cycle 1 exposure: <10%: Pass

Salt Spray Resistance - ASTM B117: Pass

Washability - ASTM D4828: Pass

Rate of Burning - ASTM D635: Pass

Surface Flammability - ASTM E162: Pass

Toxicity - Bombardier Toxic Gas Generation Test SMP800-C: Pass

Radioactivity - ASTM D3648: Pass

COMPOSITION

The high visibility flat panel is manufactured from 5005 0.9mm aluminium sheet. Custom made photoluminescent pigments are embedded in thermoset polyester carriers to integrally bond the active ingredients onto the aluminium sheet following curing at high temperature.

SUPPLY

The sign can be made to order by Ecoglo in 3 sizes with maximum viewing distances of 32 metres, 40 metres and 48 metres. Double sided versions are also available.

PRODUCT CODE	PRODUCT NAME	SIGN DEFINITION	SIGN SIZE	MAXIMUM VIEWING DISTANCE
S20-RMR5630-32m	Pictogram Right	Exit right from here	560mm x 300mm	32 metres
S20-RMR7038-40m	Pictogram Right	Exit right from here	700mm x 375mm	40 metres
S20-RMR8445-48m	Pictogram Right	Exit right from here	840mm x 450mm	48 metres
DSS20-RMD5630-32m	Pictogram Double Sided	Exit right or left from intersection	560mm x 300mm	32 metres
DSS20-RMD7038-40m	Pictogram Double Sided	Exit right or left from intersection	700mm x 375mm	40 metres
DSS20-RMD8445-48m	Pictogram Double Sided	Exit right or left from intersection	840mm x 450mm	48 metres

INSTALLATION

The standard sign is supplied with fixers for mounting flat on a wall.

Signs with brackets for ceiling or flag mounting are available - see order codes for signs and brackets below.

Mounting brackets take one sign or two signs back to back.

PRODUCT CODE	PRODUCT NAME	CEILING MOUNT BRACKET	FLAG MOUNT BRACKET
S20-RMR5630-32m	Pictogram Right	BR1-560	BR1-300
S20-RMR7038-40m	Pictogram Right	BR1-700	BR1-375
S20-RMR8445-48m	Pictogram Right	BR1-840	BR1-450
DSS20-RMD5630-32m	Pictogram Double Sided	BR1-560	BR1-300
DSS20-RMD7038-40m	Pictogram Double Sided	BR1-700	BR1-375
DSS20-RMD8445-48m	Pictogram Double Sided	BR1-840	BR1-450

Chain suspension is also available.

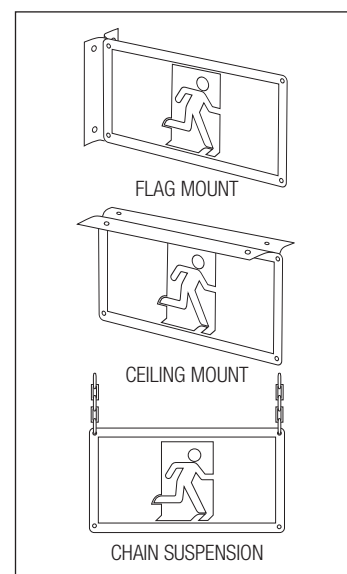

Ecoglo "Pictogram Left" S20 Signs are designed to be used in and about buildings to identify escape routes to meet NZBC Clause F8 "Signs". The signs will be clearly visible and readily understandable under all conditions of foreseeable use, including emergency conditions.

SIGN DEFINITION

Exit left from here.

COMPLIANCE

Ecoglo "Pictogram Left" S20 signs can be used to meet F8/AS1, as detailed below, or can be used in alternative solutions. Phone Ecoglo or email Engineer@ecoglo.com for design advice for alternative solutions.

PERFORMANCE

Risk Group C Building

30 minutes visibility

Minimum charging illuminance of 100 lux continuously during occupancy will ensure minimum luminance of 30 mcd for 30 minutes after failure of the main lighting.

Risk Group B Building

90 minutes visibility

Minimum charging illuminance of 350 lux continuously during occupancy will ensure minimum luminance of 30 mcd for 90 minutes after failure of the main lighting.

UV Resistance - Loss of luminance after 1000 hrs ASTM G-155 Cycle 1 exposure: <10%: Pass

Salt Spray Resistance - ASTM B117: Pass

Washability - ASTM D4828: Pass

Rate of Burning - ASTM D635: Pass

Surface Flammability - ASTM E162: Pass

Toxicity - Bombardier Toxic Gas Generation Test SMP800-C: Pass

Radioactivity - ASTM D3648: Pass

SUPPLY

The sign is available in 2 sizes - maximum viewing distance 16 metres and maximum viewing distance 24 metres.

Double sided versions are also available in the 2 sizes.

PRODUCT CODE	PRODUCT NAME	SIGN DEFINITION	SIGN SIZE	MAXIMUM VIEWING DISTANCE
S20-RML2916-16m	Pictogram Left	Exit left from here	290mm x 162mm	16 metres
S20-RML4223-24m	Pictogram Left	Exit left from here	420mm x 230mm	24 metres
DSS20-RMD2916-16m	Pictogram Double Sided	Exit left or right from intersection	290mm x 162mm	16 metres
DSS20-RMD4223-24m	Pictogram Double Sided	Exit left or right from intersection	420mm x 230mm	24 metres

COMPOSITION

The high visibility flat panel is manufactured from 5005 0.9mm aluminium sheet. Custom made photoluminescent pigments are embedded in thermoset polyester carriers to integrally bond the active ingredients onto the aluminium sheet following curing at high temperature.

INSTALLATION

The standard sign is supplied with fixers for mounting flat on a wall.

Signs with brackets for ceiling or flag mounting are available - see order codes for signs and brackets below.

Mounting brackets take one sign or two signs back to back.

PRODUCT CODE	PRODUCT NAME	CEILING MOUNT BRACKET	FLAG MOUNT BRACKET
S20-RML2916-16m	Pictogram Left	BR1-290	BR1-162
S20-RML4223-24m	Pictogram Left	BR1-420	BR1-230
DSS20-RMD2916-16m	Pictogram Double Sided	BR1-290	BR1-162
DSS20-RMD4223-24m	Pictogram Double Sided	BR1-420	BR1-230

Chain suspension is also available.

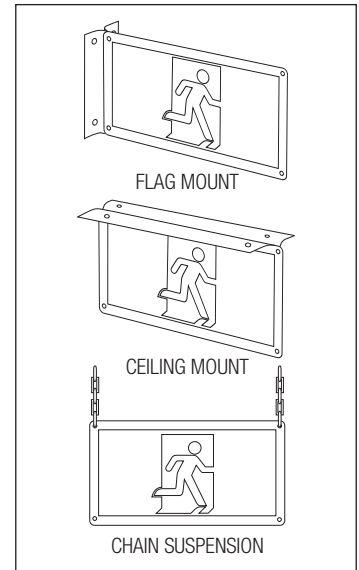
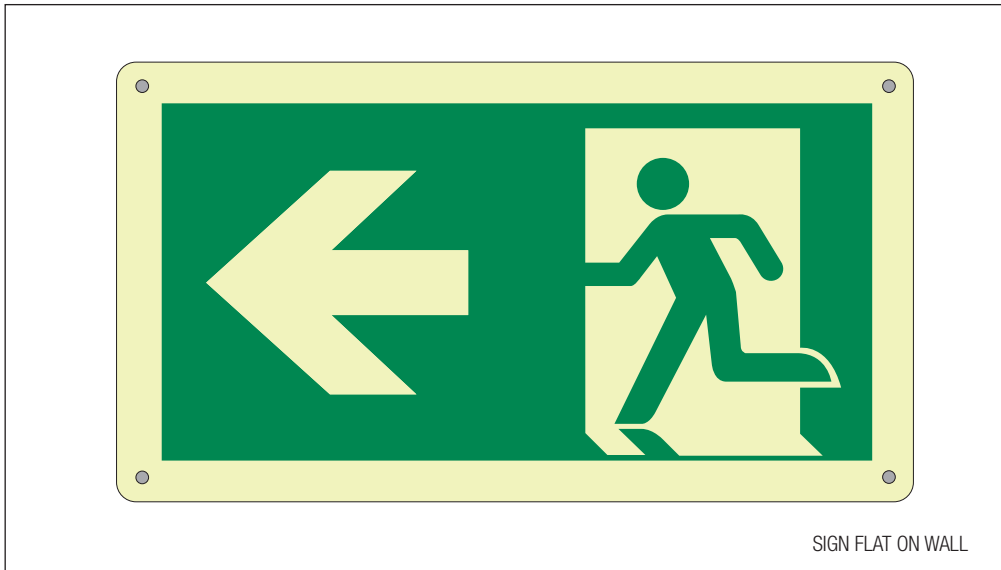

Ecoglo MADE TO ORDER “Pictogram Left” S20 Signs are designed for use in locations where Ecoglo standard signs are considered too small. The purpose of the signs is to identify escape routes in and about buildings to meet NZBC Clause F8 “Signs”. The signs will be clearly visible and readily understandable under all conditions of foreseeable use, including emergency conditions.

SIGN DEFINITION

Exit left from here.

COMPLIANCE

Ecoglo MADE TO ORDER “Pictogram Left” S20 signs can be used in alternative solutions to meet F8. Phone Ecoglo or email Engineer@ecoglo.com for design advice for alternative solutions.

PERFORMANCE

UV Resistance - Loss of luminance after 1000 hrs ASTM G-155 Cycle 1 exposure: <10%: Pass

Salt Spray Resistance - ASTM B117: Pass

Washability - ASTM D4828: Pass

Rate of Burning - ASTM D635: Pass

Surface Flammability - ASTM E162: Pass

Toxicity - Bombardier Toxic Gas Generation Test SMP800-C: Pass

Radioactivity - ASTM D3648: Pass

COMPOSITION

The high visibility flat panel is manufactured from 5005 0.9mm aluminium sheet. Custom made photoluminescent pigments are embedded in thermoset polyester carriers to integrally bond the active ingredients onto the aluminium sheet following curing at high temperature.

SUPPLY

The sign can be made to order by Ecoglo in 3 sizes with maximum viewing distances of 32 metres, 40 metres and 48 metres. Double sided versions are also available.

PRODUCT CODE	PRODUCT NAME	SIGN DEFINITION	SIGN SIZE	MAXIMUM VIEWING DISTANCE
S20-RML5630-32m	Pictogram Left	Exit left from here	560mm x 300mm	32 metres
S20-RML7038-40m	Pictogram Left	Exit left from here	700mm x 375mm	40 metres
S20-RML8445-48m	Pictogram Left	Exit left from here	840mm x 450mm	48 metres
DSS20-RMD5630-32m	Pictogram Double Sided	Exit left or right from intersection	560mm x 300mm	32 metres
DSS20-RMD7038-40m	Pictogram Double Sided	Exit left or right from intersection	700mm x 375mm	40 metres
DSS20-RMD8445-48m	Pictogram Double Sided	Exit left or right from intersection	840mm x 450mm	48 metres

INSTALLATION

The standard sign is supplied with fixers for mounting flat on a wall.

Signs with brackets for ceiling or flag mounting are available - see order codes for signs and brackets below.

Mounting brackets take one sign or two signs back to back.

PRODUCT CODE	PRODUCT NAME	CEILING MOUNT BRACKET	FLAG MOUNT BRACKET
S20-RML5630-32m	Pictogram Left	BR1-560	BR1-300
S20-RML7038-40m	Pictogram Left	BR1-700	BR1-375
S20-RML8445-48m	Pictogram Left	BR1-840	BR1-450
DSS20-RMD5630-32m	Pictogram Double Sided	BR1-560	BR1-300
DSS20-RMD7038-40m	Pictogram Double Sided	BR1-700	BR1-375
DSS20-RMD8445-48m	Pictogram Double Sided	BR1-840	BR1-450

Chain suspension is also available.

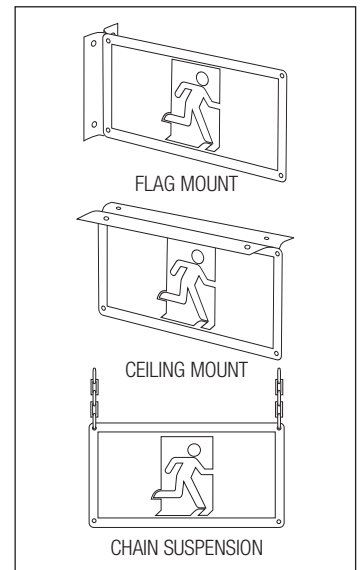

Ecoglo "Double Arrow" S20 Signs are designed to be used in and about buildings to identify escape routes to meet NZBC Clause F8 "Signs". The signs will be clearly visible and readily understandable under all conditions of foreseeable use, including emergency conditions.

SIGN DEFINITION

Exit right or left from here.

COMPLIANCE

Ecoglo "Double Arrow" S20 signs can be used in F8 Alternative Solutions as detailed below. Phone Ecoglo or email Engineer@ecoglo.com for design advice for alternative solutions.

PERFORMANCE

Risk Group C Building

30 minutes visibility

Minimum charging illuminance of 100 lux continuously during occupancy will ensure minimum luminance of 30 mcd for 30 minutes after failure of the main lighting.

Risk Group B Building

90 minutes visibility

Minimum charging illuminance of 350 lux continuously during occupancy will ensure minimum luminance of 30 mcd for 90 minutes after failure of the main lighting.

UV Resistance - Loss of luminance after 1000 hrs ASTM G-155 Cycle 1 exposure: <10%: Pass

Salt Spray Resistance - ASTM B117: Pass

Washability - ASTM D4828: Pass

Rate of Burning - ASTM D635: Pass

Surface Flammability - ASTM E162: Pass

Toxicity - Bombardier Toxic Gas Generation Test SMP800-C: Pass

Radioactivity - ASTM D3648: Pass

SUPPLY

The sign is available in 2 sizes - maximum viewing distance 16 metres and maximum viewing distance 24 metres.

Double sided versions are also available in the 2 sizes.

PRODUCT CODE	PRODUCT NAME	SIGN DEFINITION	SIGN SIZE	MAXIMUM VIEWING DISTANCE
S20-RMRL2916-16m	Double Arrow	Exit right or left from here	290mm x 162mm	16 metres
S20-RMRL4223-24m	Double Arrow	Exit right or left from here	420mm x 230mm	24 metres
DSS20-RMRL2916-16m	Double Arrow Double Sided	Exit right or left from here	290mm x 162mm	16 metres
DSS20-RMRL4223-24m	Double Arrow Double Sided	Exit right or left from here	420mm x 230mm	24 metres

COMPOSITION

The high visibility flat panel is manufactured from 5005 0.9mm aluminium sheet. Custom made photoluminescent pigments are embedded in thermoset polyester carriers to integrally bond the active ingredients onto the aluminium sheet following curing at high temperature.

INSTALLATION

The standard sign is supplied with fixers for mounting flat on a wall.

Signs with brackets for ceiling or flag mounting are available - see order codes for signs and brackets below.

Mounting brackets take one sign or two signs back to back.

PRODUCT CODE	PRODUCT NAME	CEILING MOUNT BRACKET	FLAG MOUNT BRACKET
S20-RMRL2916-16m	Double Arrow	BR1-290	BR1-162
S20-RMRL4223-24m	Double Arrow	BR1-420	BR1-230
DSS20-RMRL2916-16m	Double Arrow Double Sided	BR1-290	BR1-162
DSS20-RMRL4223-24m	Double Arrow Double Sided	BR1-420	BR1-230

Chain suspension is also available.

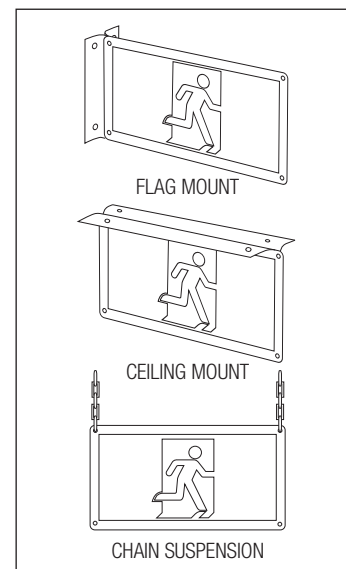
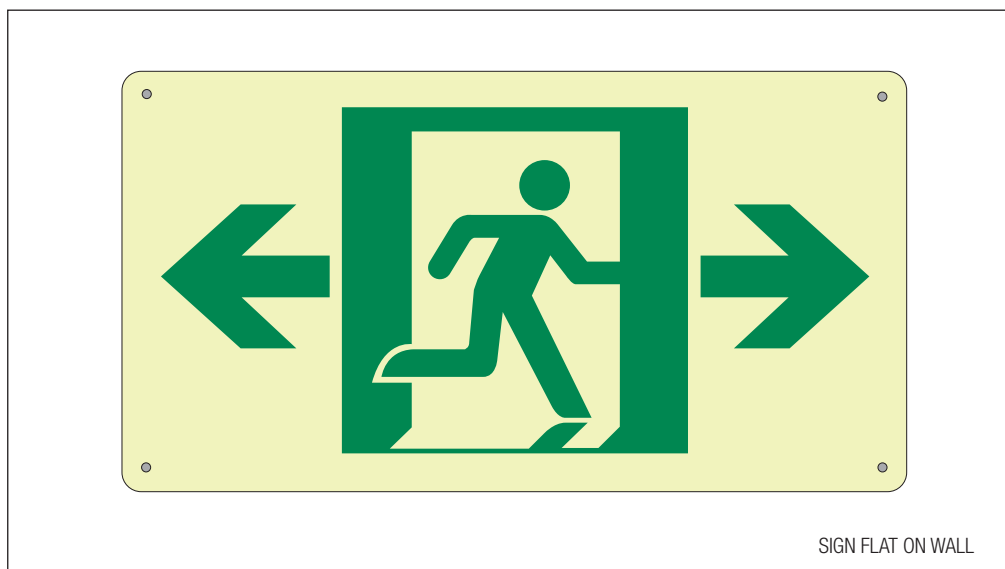

Ecoglo "Double Arrow Hi Vis" S20 Signs are designed to be used in and about buildings to identify escape routes to meet NZBC Clause F8 "Signs". The signs will be clearly visible and readily understandable under all conditions of foreseeable use, including emergency conditions.

SIGN DEFINITION

Exit right or left from here.

COMPLIANCE

Ecoglo "Double Arrow Hi Vis" S20 signs can be used in F8 Alternative Solutions as detailed below. Phone Ecoglo or email Engineer@ecoglo.com for design advice for alternative solutions.

PERFORMANCE

Risk Group C Building

30 minutes visibility

Minimum charging illuminance of 100 lux continuously during occupancy will ensure minimum luminance of 30 mcd for 30 minutes after failure of the main lighting.

Risk Group B Building

90 minutes visibility

Minimum charging illuminance of 350 lux continuously during occupancy will ensure minimum luminance of 30 mcd for 90 minutes after failure of the main lighting.

UV Resistance - Loss of luminance after 1000 hrs ASTM G-155 Cycle 1 exposure: <10%: Pass

Salt Spray Resistance - ASTM B117: Pass

Washability - ASTM D4828: Pass

Rate of Burning - ASTM D635: Pass

Surface Flammability - ASTM E162: Pass

Toxicity - Bombardier Toxic Gas Generation Test SMP800-C: Pass

Radioactivity - ASTM D3648: Pass

SUPPLY

The sign is available in 2 sizes - maximum viewing distance 16 metres and maximum viewing distance 24 metres.

Double sided versions are also available in the 2 sizes.

PRODUCT CODE	PRODUCT NAME	SIGN DEFINITION	SIGN SIZE	MAXIMUM VIEWING DISTANCE
S20-RMRL2916HV-16m	Double Arrow Hi Vis	Exit right or left from here	290mm x 162mm	16 metres
S20-RMRL4223HV-24m	Double Arrow Hi Vis	Exit right or left from here	420mm x 230mm	24 metres
DSS20-RMRL2916HV-16m	Double Arrow Hi Vis Double Sided	Exit right or left from here	290mm x 162mm	16 metres
DSS20-RMRL4223HV-24m	Double Arrow Hi Vis Double Sided	Exit right or left from here	420mm x 230mm	24 metres

COMPOSITION

The high visibility flat panel is manufactured from 5005 0.9mm aluminium sheet. Custom made photoluminescent pigments are embedded in thermoset polyester carriers to integrally bond the active ingredients onto the aluminium sheet following curing at high temperature.

INSTALLATION

The standard sign is supplied with fixers for mounting flat on a wall.

Signs with brackets for ceiling or flag mounting are available - see order codes for signs and brackets below.

Mounting brackets take one sign or two signs back to back.

PRODUCT CODE	PRODUCT NAME	CEILING MOUNT BRACKET	FLAG MOUNT BRACKET
S20-RMRL2916HV-16m	Double Arrow Hi Vis	BR1-290	BR1-162
S20-RMRL4223HV-24m	Double Arrow Hi Vis	BR1-420	BR1-230
DSS20-RMRL2916HV-16m	Double Arrow Hi Vis Double Sided	BR1-290	BR1-162
DSS20-RMRL4223HV-24m	Double Arrow Hi Vis Double Sided	BR1-420	BR1-230

Chain suspension is also available.



SIGN FLAT ON A DOOR

Ecoglo "Emergency Exit" S20 Signs are designed to be used in and about buildings to identify escape routes to meet NZBC Clause F8 "Signs". The signs will be clearly visible and readily understandable under all conditions of foreseeable use, including emergency conditions.

SIGN DEFINITION

Use this door only to exit in an emergency.

COMPLIANCE

Ecoglo "Emergency Exit" S20 signs can be used to meet F8/AS1, as detailed below, or can be used in alternative solutions. Phone Ecoglo or email Engineer@ecoglo.com for design advice for alternative solutions.

PERFORMANCE

Risk Group C Building
30 minutes visibility
Minimum charging illuminance of 100 lux continuously during occupancy will ensure minimum luminance of 30 mcd for 30 minutes after failure of the main lighting.

Risk Group B Building
90 minutes visibility
Minimum charging illuminance of 350 lux continuously during occupancy will ensure minimum luminance of 30 mcd for 90 minutes after failure of the main lighting.

UV Resistance - Loss of luminance after 1000 hrs ASTM G-155
Cycle 1 exposure: <10%: Pass
Salt Spray Resistance - ASTM B117: Pass
Washability - ASTM D4828: Pass
Rate of Burning - ASTM D635: Pass

Surface Flammability - ASTM E162: Pass
Toxicity - Bombardier Toxic Gas Generation Test SMP800-C: Pass
Radioactivity - ASTM D3648: Pass

SUPPLY

The sign is available in 2 sizes - maximum viewing distance 16 metres and maximum viewing distance 24 metres.

PRODUCT CODE	PRODUCT NAME	SIGN DEFINITION	SIGN SIZE	MAXIMUM VIEWING DISTANCE
S20-EE6128-16m	Emergency Exit	Use this door only to exit in an emergency	610mm x 280mm	16 metres
S20-EE7835-24m	Emergency Exit	Use this door only to exit in an emergency	785mm x 350mm	24 metres

COMPOSITION

The high visibility flat panel is manufactured from 5005 0.9mm aluminium sheet. Custom made photoluminescent pigments are embedded in thermoset polyester carriers to integrally bond the active ingredients onto the aluminium sheet following curing at high temperature.

INSTALLATION

The standard sign is supplied with fixers for mounting flat on a door or wall.



SIGN FLAT ON A DOOR

Ecoglo "No Exit" S20 Signs are designed to be used in and about buildings to identify escape routes to meet NZBC Clause F8 "Signs". The signs will be clearly visible and readily understandable under all conditions of foreseeable use, including emergency conditions.

SIGN DEFINITION

Do not use this door to exit in an emergency.

COMPLIANCE

Ecoglo "No Exit" S20 signs can be used to meet F8/AS1, as detailed below, or can be used in alternative solutions. Phone Ecoglo or email Engineer@ecoglo.com for design advice for alternative solutions.

PERFORMANCE

Risk Group C Building

30 minutes visibility

Minimum charging illuminance of 100 lux continuously during occupancy will ensure minimum luminance of 30 mcd for 30 minutes after failure of the main lighting.

Risk Group B Building

90 minutes visibility

Minimum charging illuminance of 350 lux continuously during occupancy will ensure minimum luminance of 30 mcd for 90 minutes after failure of the main lighting.

UV Resistance - Loss of luminance after 1000 hrs ASTM G-155 Cycle 1 exposure: <10%: Pass

Salt Spray Resistance - ASTM B117: Pass

Washability - ASTM D4828: Pass

Rate of Burning - ASTM D635: Pass

Surface Flammability - ASTM E162: Pass

Toxicity - Bombardier Toxic Gas Generation Test SMP800-C: Pass

Radioactivity - ASTM D3648: Pass

SUPPLY

The sign is available in 1 size with a maximum viewing distance of 16 metres.

PRODUCT CODE	PRODUCT NAME	SIGN DEFINITION	SIGN SIZE	MAXIMUM VIEWING DISTANCE
S20-NE4113-16m	No Exit	Do not use this door to exit in an emergency	410mm x 133mm	16 metres

COMPOSITION

The high visibility flat panel is manufactured from 5005 0.9mm aluminium sheet. Custom made photoluminescent pigments are embedded in thermoset polyester carriers to integrally bond the active ingredients onto the aluminium sheet following curing at high temperature.

INSTALLATION

The standard sign is supplied with fixers for mounting flat on a door or wall.

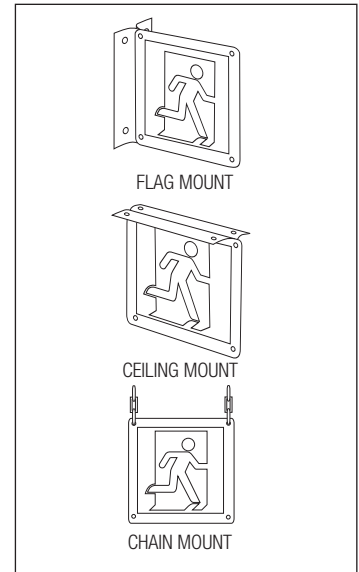
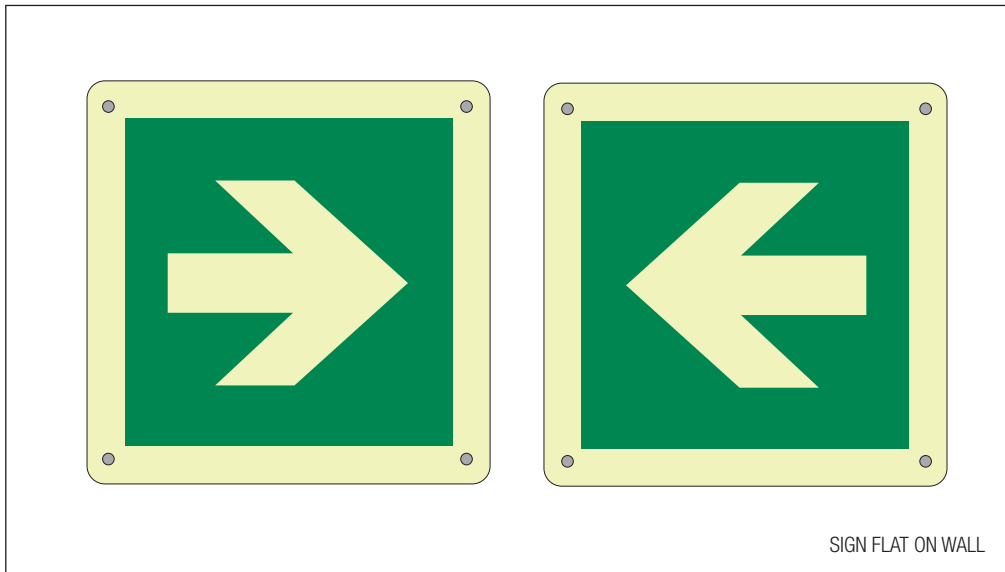

Ecoglo "Arrow" S20 Signs are designed to be used in and about buildings to identify escape routes to meet NZBC Clause F8 "Signs". The signs will be clearly visible and readily understandable under all conditions of foreseeable use, including emergency conditions.

SIGN DEFINITION

Travel in this direction.

COMPLIANCE

Ecoglo "Arrow" S20 signs can be used in F8 Alternative Solutions as detailed below.
Phone Ecoglo or email Engineer@ecoglo.com for design advice for alternative solutions.

PERFORMANCE

Risk Group C Building

30 minutes visibility

Minimum charging illuminance of 100 lux continuously during occupancy will ensure minimum luminance of 30 mcd for 30 minutes after failure of the main lighting.

Risk Group B Building

90 minutes visibility

Minimum charging illuminance of 350 lux continuously during occupancy will ensure minimum luminance of 30 mcd for 90 minutes after failure of the main lighting.

UV Resistance - Loss of luminance after 1000 hrs ASTM G-155 Cycle 1 exposure: <10%: Pass

Salt Spray Resistance - ASTM B117: Pass

Washability - ASTM D4828: Pass

Rate of Burning - ASTM D635: Pass

Surface Flammability - ASTM E162: Pass

Toxicity - Bombardier Toxic Gas Generation Test SMP800-C: Pass
Radioactivity - ASTM D3648: Pass

SUPPLY

The sign is available in 3 sizes for use with other F8 signs.

PRODUCT CODE	PRODUCT NAME	SIGN DEFINITION	SIGN SIZE
S20-AR1313	Arrow	Travel in this direction	133mm x 133mm
S20-AR1616	Arrow	Travel in this direction	162mm x 162mm
S20-AR2323	Arrow	Travel in this direction	230mm x 230mm

COMPOSITION

The high visibility flat panel is manufactured from 5005 0.9mm aluminium sheet. Custom made photoluminescent pigments are embedded in thermoset polyester carriers to integrally bond the active ingredients onto the aluminium sheet following curing at high temperature.

INSTALLATION

The standard sign is supplied with fixers for mounting flat on a wall.

Signs with brackets for ceiling or flag mounting are available - see order codes for signs and brackets below.

Mounting brackets take one sign or two signs back to back.

PRODUCT CODE	PRODUCT NAME	CEILING MOUNT BRACKET	FLAG MOUNT BRACKET
S20-AR1313	Arrow	BR1-133	BR1-133
S20-AR1616	Arrow	BR1-162	BR1-162
S20-AR2323	Arrow	BR1-230	BR1-230

Chain suspension is also available.

2018 V1

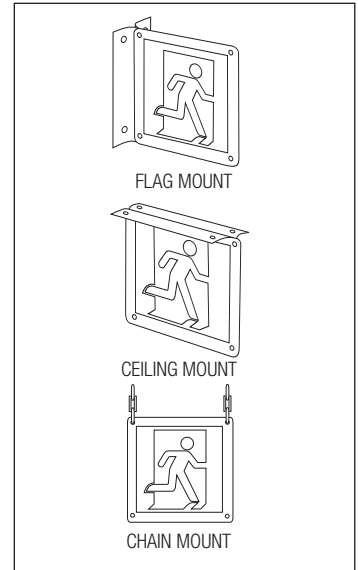

Ecoglo “Accessible” S20 Signs are designed to be used in and about buildings to identify accessible routes and facilities provided specifically for people with disabilities to meet NZBC Clauses F8 Signs and D1 Access Routes.

The sign will be clearly visible and readily understandable under all conditions of foreseeable use, including emergency conditions.

SIGN DEFINITION

Access and facilities for people with disabilities.

COMPLIANCE

Ecoglo “Accessible” S20 signs can be used to meet both F8/AS1 and D1/AS1.

PERFORMANCE

Ecoglo “Accessible” S20 Signs being photoluminescent will continue to be visible indoors after failure of the main lighting, and outdoors after dark.

UV Resistance - Loss of luminance after 1000 hrs ASTM G-155 Cycle 1 exposure: <10%: Pass

Salt Spray Resistance - ASTM B117: Pass

Washability - ASTM D4828: Pass

Rate of Burning - ASTM D635: Pass

Surface Flammability - ASTM E162: Pass

Toxicity - Bombardier Toxic Gas Generation Test SMP800-C: Pass

Radioactivity - ASTM D3648: Pass

SUPPLY

The sign is available in the following size.

PRODUCT CODE	PRODUCT NAME	SIGN DEFINITION	SIGN SIZE
S20-AC1616	Accessible	Access and facilities for people with disabilities	162mm x 162mm

COMPOSITION

The high visibility flat panel is manufactured from 5005 0.9mm aluminium sheet. Custom made photoluminescent pigments are embedded in thermoset polyester carriers to integrally bond the active ingredients onto the aluminium sheet following curing at high temperature.

INSTALLATION

The standard sign is supplied with fixers for mounting flat on a wall.

Signs with brackets for ceiling or flag mounting are available - see order codes for signs and brackets below.

PRODUCT CODE	PRODUCT NAME	CEILING MOUNT BRACKET	FLAG MOUNT BRACKET
S20-AC1616	Accessible	BR1-162	BR1-162

Chain suspension is also available.



The Ecoglo BR2 Series of mounted Exit signs are designed for architectural perfection. The chic aluminium cover plate offers a sleek architectural appearance that will complement any interior space.

Suitable for architectural designs where first class aesthetics and performance are required.

COMPOSITION

Ecoglo BR2 Architectural brackets include:

- 4mm thick clear acrylic faceplate with bevelled edge;
- 4mm thick green acrylic backing plate;
- Anodised aluminium mounting plates.

INSTALLATION

All bracket kits are supplied with two pieces of 4mm acrylic and all required fixers.

Signs can be mounted flat against a wall using standoff pegs or from the ceiling or wall using a mounting and cover plate.

Brackets can take one sign or two signs back to back.

SUPPLY

Architectural brackets are available in 2 sizes to suit 16 metres viewing distance and 24 metres viewing distance.

PRODUCT CODE	PRODUCT NAME	SIGN SIZE
--------------	--------------	-----------

SURFACE MOUNT. Comes with 20mm spacers

BR2-S20-RM2916-16m	Pictogram	290mm x 162mm x 10mm
BR2-S20-RML2916-16m	Pictogram Left	290mm x 162mm x 10mm
BR2-S20-RMR2916-16m	Pictogram Right	290mm x 162mm x 10mm
BR2-S20-RMRL2916-16m	Pictogram Double Arrow	290mm x 162mm x 10mm

BR2-S20-RM4223-24m	Pictogram	420mm x 230mm x 10mm
BR2-S20-RML4223-24m	Pictogram Left	420mm x 230mm x 10mm
BR2-S20-RMR4223-24m	Pictogram Right	420mm x 230mm x 10mm
BR2-S20-RMRL4223-24m	Pictogram Double Arrow	420mm x 230mm x 10mm
BR2-S20-EX2916-24m	Exit	290mm x 162mm x 10mm

FLAG MOUNT. Comes with flag mount plate and cover

BR2-162-S20-RM2916-16m	Pictogram	290mm x 162mm x 10mm
BR2-162-S20-RML2916-16m	Pictogram Left	290mm x 162mm x 10mm
BR2-162-S20-RMR2916-16m	Pictogram Right	290mm x 162mm x 10mm
BR2-162-DSS20-RMD2916-16m	Double Sided Pictogram Directional	290mm x 162mm x 10mm
BR2-162-S20-RMRL2916-16m	Pictogram Double Arrow	290mm x 162mm x 10mm
BR2-162-DSS20-RMRL2916-16m	Double Sided Pictogram Double Arrow	290mm x 162mm x 10mm

BR2-162-S20-RM4223-24m	Pictogram	420mm x 230mm x 10mm
BR2-162-S20-RML4223-24m	Pictogram Left	420mm x 230mm x 10mm
BR2-162-S20-RMR4223-24m	Pictogram Right	420mm x 230mm x 10mm
BR2-162-DSS20-RMD4223-24m	Double Sided Pictogram Directional	420mm x 230mm x 10mm
BR2-162-S20-RMRL4223-24m	Pictogram Double Arrow	420mm x 230mm x 10mm
BR2-162-DSS20-RMRL4223-24m	Double Sided Pictogram Double Arrow	420mm x 230mm x 10mm
BR2-162-S20-EX2916-24m	Exit	290mm x 162mm x 10mm

CEILING MOUNT. Comes with ceiling mount plate and cover

BR2-290-S20-RM2916-16m	Pictogram	290mm x 162mm x 10mm
BR2-290-S20-RML2916-16m	Pictogram Left	290mm x 162mm x 10mm
BR2-290-S20-RMR2916-16m	Pictogram Right	290mm x 162mm x 10mm
BR2-290-DSS20-RMD2916-16m	Double Sided Pictogram Directional	290mm x 162mm x 10mm
BR2-290-S20-RMRL2916-16m	Pictogram Double Arrow	290mm x 162mm x 10mm
BR2-290-DSS20-RMRL2916-16m	Double Sided Pictogram Double Arrow	290mm x 162mm x 10mm

BR2-290-S20-RM4223-24m	Pictogram	420mm x 230mm x 10mm
BR2-290-S20-RMR4223-24m	Pictogram Right	420mm x 230mm x 10mm
BR2-290-S20-RML4223-24m	Pictogram Left	420mm x 230mm x 10mm
BR2-290-DSS20-RMD4223-24m	Double Sided Pictogram Directional	420mm x 230mm x 10mm
BR2-290-S20-RMRL4223-24m	Pictogram Double Arrow	420mm x 230mm x 10mm
BR2-290-DSS20-RMRL4223-24m	Double Sided Pictogram Double Arrow	420mm x 230mm x 10mm
BR2-290-S20-EX2916-24m	Exit	290mm x 162mm x 10mm



Surface Mount



Ceiling Mount



Flag Mount

Incorporating both Ecoglo patented photoluminescent technology and next generation LEDs, the Ecoglo Hybrid Exit Sign is the ultimate solution in emergency exit signage. Requiring no battery backup, the hybrid sign is effective in all lighting scenarios. Designed to be used in and about buildings to meet NZBC Clause F8 “Signs”, the signs will be clearly visible and readily understandable under all conditions of foreseeable use, including emergency conditions.

COMPLIANCE

Ecoglo Hybrid Exit Signs can be used to meet F8/AS1 or can be used in alternative solutions.

Email engineer@ecoglo.com for design advice for Performance Solutions.

PERFORMANCE

Provides a minimum of 90 minutes of visibility after failure of the main lighting.

INPUT

120/240 Vac, 50/60 Hz, Single Sided Sign
120/240 Vac, 50/60 Hz, Double Sided Sign

RATED POWER CONSUMPTION

2.25W Single Sided Sign
4.5W Double Sided Sign

SUPPLY

The signs are currently available in one size. ‘Pictogram’ signs have a maximum viewing distance of 16 metres, while ‘Exit’ signs have a maximum viewing distance of 24 metres.

PRODUCT CODE	PRODUCT DESCRIPTION	GRAPHICS INCLUDED	MAXIMUM VIEWING DISTANCE
HYU1	Single Sided Hybrid Sign	1 x RM, 1 x RMR, 1 x RML	16 metres
HYU1-RMD	Single Sided Hybrid Sign	1 x RM Double Arrow	16 metres
HYU1-EX	Single Sided Hybrid Sign	1 x Exit	24 metres
HYU1-EXR	Single Sided Hybrid Sign	1 x Exit Right	24 metres
HYU1-EXL	Single Sided Hybrid Sign	1 x Exit Left	24 metres
HYU1-EXCB	Single Sided Hybrid Sign	1 x Exit Low Light Black	24 metres
HYU2	Double Sided Hybrid Sign	2 x RM, 1 x RMR, 1 x RML	16 metres
HYU2-RMRL	Double Sided Hybrid Sign	2 x RM Double Arrow	16 metres
HYU2-EX	Double Sided Hybrid Sign	2 x Exit	24 metres
HYU2-EXRL	Double Sided Hybrid Sign	1 x Exit Right, 1 x Exit Left	24 metres
HYU2-EXCB	Double Sided Hybrid Sign	1 x Exit Low Light Black	24 metres

Above signs include one or more of graphics shown below.



RM
Exit straight on from here



RML
Exit left from here



RMR
Exit right from here



RM DOUBLE ARROW
Exit right or left from here



EXIT
Exit straight on from here



EXIT LEFT
Exit left from here



EXIT RIGHT
Exit right from here



EXIT LOW LIGHT BLACK
Exit straight on from here

See over for features and specifications etc.

2018 V3

PRODUCT FEATURES

- LED/Photoluminescent Exit Sign System
- Meets NZBC F8/AS1
- No batteries or backup power required for power outages
- High efficiency low power consumption LED charging source
- Works in all lighting scenarios
- Universal mount – convenient Turn & Lock™ mounting system for quick and versatile installation
- Non-toxic, non-radioactive photoluminescent technology
- Complies with New Zealand and Australia electrical safety requirements
- UL 924 tested and listed models available
- UL certified for 120 minute operating time at 16 metres

INTERNAL SPECIFICATIONS

AC LED: standard 120/240 VAC input

SELF POWERED: Photoluminescent sealed plates to provide extended emergency duration. Performance Certified.

PRODUCT WEIGHT

Single Sided Sign: 2.34kg

Double Sided Sign: 2.79kg

INSTALLATION

Versatile mounting hardware provides for quick installation and minimised downtime.

COMPREHENSIVE WARRANTY

10 years on enclosure, 5 years on LED and driver, plus 30 years on photoluminescence.

DIMENSIONS



SURFACE MOUNT

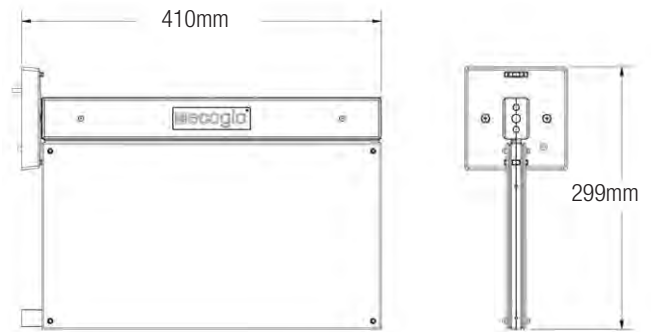

FLAG MOUNT

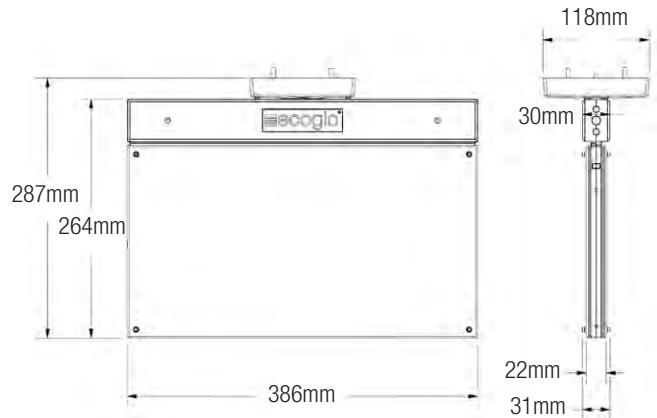

CEILING MOUNT

UL listed models available on request



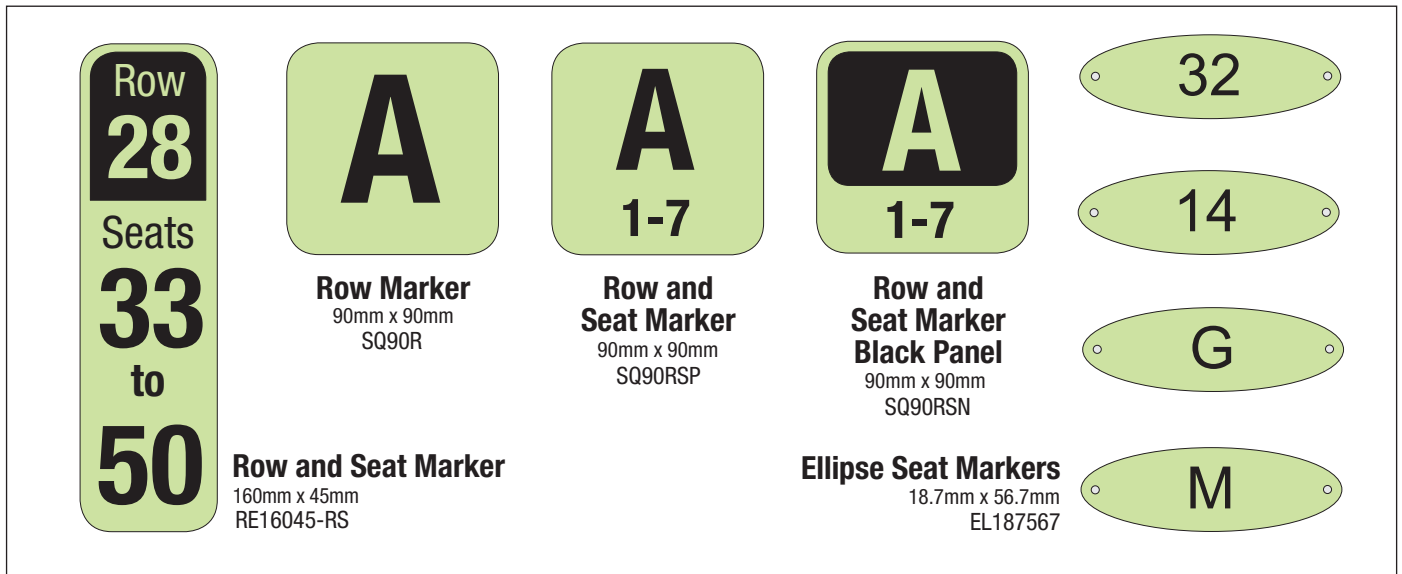

Ecoglo's highly visible photoluminescent Aisle Markers and Seat Markers are designed to readily guide customers to their seats. Working equally well in light, dark and dim conditions they reduce disruption to other customers, increase the efficiency of ushers, and make it easy for a customer to visit concessions or other facilities.

The photoluminescent Aisle and Seat Markers are designed to be visible for the length of a performance (concert, movies, sporting event, etc) to enhance the orderly movement of people to and from their seats. The basic design consists of black text on a glowing background with custom layouts also available.



Supply

The Aisle Marker can indicate row only or also include seat number ranges.

PRODUCT CODE	PRODUCT NAME	SIGN SIZE
SQ90R	Row Marker	90mm x 90mm
SQ90RSP	Row and Seat Marker	90mm x 90mm
SQ90RSN	Row and Seat Marker Black Panel	90mm x 90mm
RE16045-RS	Row and Seat Marker	160mm x 45mm

The Seat Marker indicates number or letter of seat.

PRODUCT CODE	PRODUCT NAME	SIGN SIZE
EL187567	Ellipse Seat Marker	18.7mm x 56.7mm

Composition

The high visibility flat panel is manufactured from 5005 0.9mm aluminium sheet. Custom made photoluminescent pigments are embedded in thermoset polyester carriers to integrally bond the active ingredients onto the aluminium sheet following curing at high temperature.

1. Identification

Product Name

Ecoglo S20 Flat Panel Signs including: EX2313-16m, EX2916-24m, RM2916-16m, RM4223-24m, RM5630-32m, RM7038-40m, RM8445-48m, RM2916HV-16m, RM4223HV-24m, RMR2916-16m, RMR4223-24m, RML2916-16m, RML4223-24m, RML5630-32m, RML7038-40m, RML8445-48m, RMR5630-32m, RMR7038-40m, RMR8445-48m, RM1616UN-16m, RM2323UN-24m, RMRL2916-16m, RMRL4223-24m, RMRL-2916HV-16m, RMRL4223HV-24m, EE6128-16m, EE7835-24m, NE4113-16m, AR1313, AR1616-16m, AR2323-24m, SQ-60, AC1616

Manufacturer Details

Company: Ecoglo International Ltd
Address: 77 Kingsley St, Christchurch 8440, New Zealand
Phone No: +64 3 348 3781

2. Hazard Identification

Not classified as hazardous or dangerous as per GHS.

3. Composition/information on ingredients

Component	CAS No.	Proportion
Aluminium Alloy (5005)	-	40-70%
Strontium Aluminate based photoluminescent pigment	-	10-40%
Cross-linked thermoset polyester based resins	-	10-30%
Other components	-	< 1%

4. First-aid measures No special measures required.

5. Fire-fighting measures No special measures required.

6. Accidental release measures Not applicable.

7. Handling and storage Cut edges may be sharp. No special storage requirements.

8. Exposure controls and personal protection Wear gloves when handling.

9. Physical and chemical properties

Appearance:	Solid sheet material
Odour:	N/A
Melting point:	N/A
Specific gravity:	2.2-2.7 g/cc
Volatile:	N/A
Vapour pressure:	N/A
Vapour density:	N/A
Solubility in water:	Insoluble
Flammability:	Not easily combustible. Passes Bombardier SMP 800-C Toxic gas generation test
Explosivity:	Not explosive

10. Stability and reactivity

Hazardous reactions:	None known
Radioactivity:	Not Radioactive

11. Toxicological information No toxicological properties.

12. Ecological information No ecological hazards.

13. Disposal considerations Offcuts can be sent for aluminium recycling.

14. Transport information Not restricted.

15. Regulatory information None applicable to product.

16. Any other relevant information None.

This information is offered in good faith to the best of our current knowledge. No warranty, expressed or implied, regarding the accuracy of this data, the hazards connected with use of the material, or the results to be obtained from the use thereof, is made. Ecoglo International Ltd. assumes no responsibility for damage or injury from the use of this product.

Ecoglo Escape Route Products

 ecoglo®
VISIBLY BETTER

Escape Route Products to meet F6 Visibility in Escape Routes

F4-171 Step Nosing 68mm x 33mm

Available in standard lengths from 600mm to 1500mm in 100mm increments

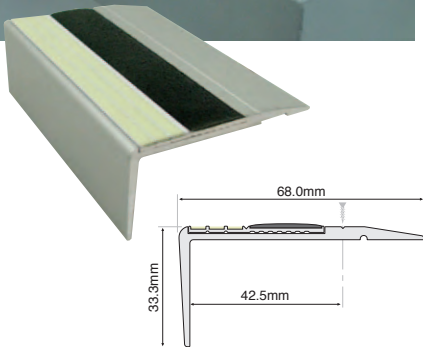
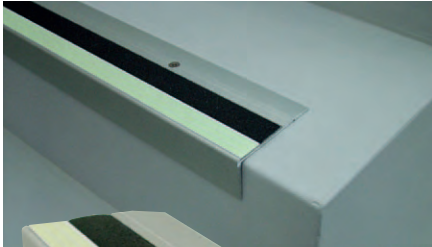

- Supplied pre-drilled with fixers.
- Adhesive and caulking gun available separately
- Custom cutting is available from 2450mm and 3060mm lengths

E2-071 Step Edge Contrast 37mm

Available in standard lengths from 600mm to 1500mm in 100mm increments

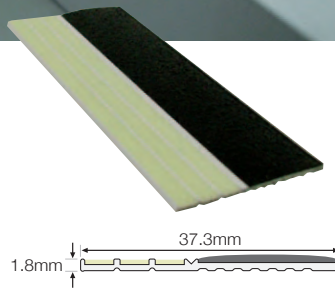
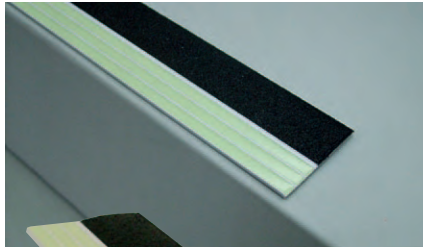

- Adhesive and caulking gun available separately
- Custom cutting is available from 2450mm and 3060mm lengths

E2-071 Polyurethane adhesive fixing
E2-071P Punched for screw fixing

F14-175 Step Nosing 75mm x 10mm

Available in standard lengths from 600mm to 1500mm in 100mm increments

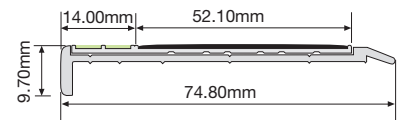
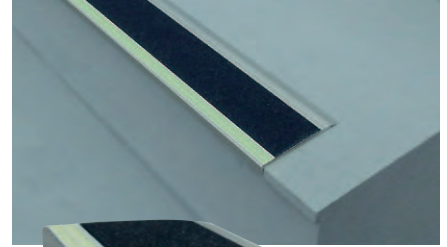

- Supplied pre-drilled with fixers.
- Adhesive and caulking gun available separately
- Custom cutting is available from 2450mm and 3060mm lengths
- Custom colours are available to meet AS 1428.1 luminance contrast for any surface colour

F15-175 Step Nosing 75mm x 33mm

Available in standard lengths from 600mm to 1500mm in 100mm increments

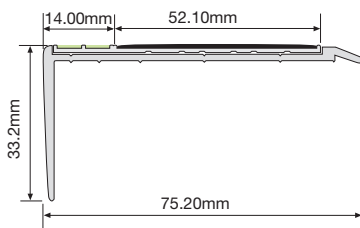
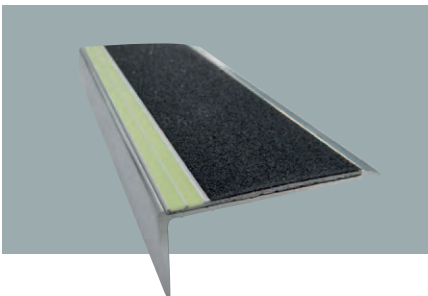

- Supplied pre-drilled with fixers.
- Adhesive and caulking gun available separately
- Custom cutting is available from 2450mm and 3060mm lengths

E14-075 Step Edge Contrast 64mm

Available in standard lengths from 600mm to 1500mm in 100mm increments

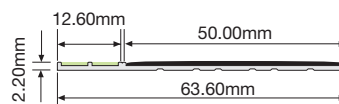
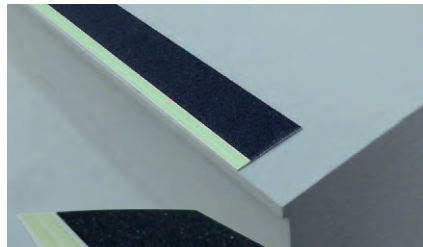

- Adhesive and caulking gun available separately
- Custom cutting is available from 2450mm and 3060mm lengths
- Custom colours are available to meet AS 1428.1 luminance contrast for any surface colour

E14-075 Polyurethane adhesive fixing
E14-075P Punched for screw fixing

Escape Route Products to meet F6 Visibility in Escape Routes

MS-26 Handrail Wall Strip 26mm
Available in 1000mm lengths

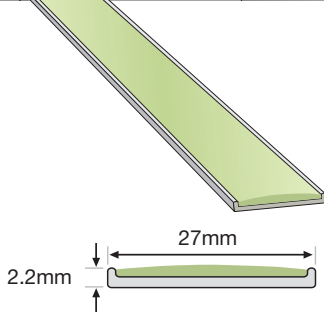
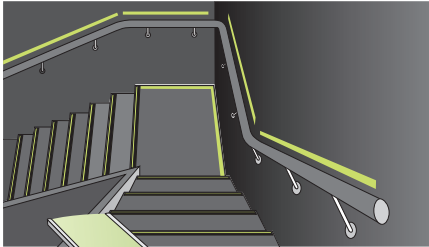

MS-26T-1000 Release tape pre-fitted

H3-001 Handrail Marker 16mm
Available in 1000mm and 1500mm lengths

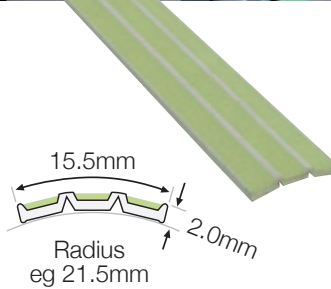

H3-001T-1000 Release tape pre-fitted
H3-001T-1500 Release tape pre-fitted

G3-001 Guidance Strip 16mm
Available in 1000mm lengths

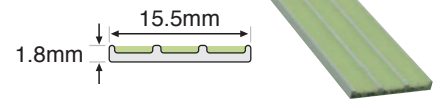

G3-001-1000 Polyurethane adhesive fixing
G3-001P-1000 Punched for screw fixing
G3-001T-1000 Release tape pre-fitted
G3-001T-1500 Release tape pre-fitted

G4-001 Guidance Strip 12.5mm
Available in 1000mm lengths

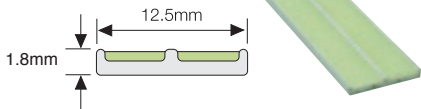

G4-001-1000 Polyurethane adhesive fixing
G4-001T-1000 Release tape pre-fitted

Escape Route Products to meet F6 Visibility in Escape Routes

T5-101 Path Marker

Available in 1000mm lengths

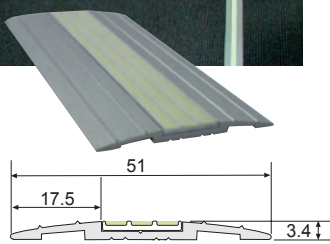

T5-101-1000 Polyurethane adhesive fixing
T5-101P-1000 Punched for screw fixing

G7-100 Solaris Path Marker

Available in 1000mm lengths

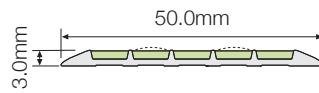

G7-100 Polyurethane adhesive fixing
G7P-100 Punched for screw fixing
G7T-100 Release tape pre-fitted

T6-101 Path Marker

Available in 1000mm lengths

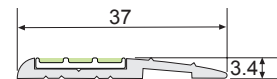
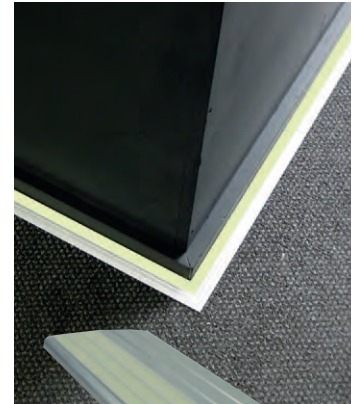

T6-101-1000 Polyurethane adhesive fixing
T6-101P-1000 Punched for screw fixing

Door Handle Marker

Use this to highlight a door handle in an emergency

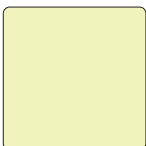

60mm x 60mm

SQ60 - Release tape pre-fitted

Miscellaneous Products

Adhesive for Escape Route Products

Caulking Gun

CLKGUN-600ml

To take 600ml Adhesive Sausage

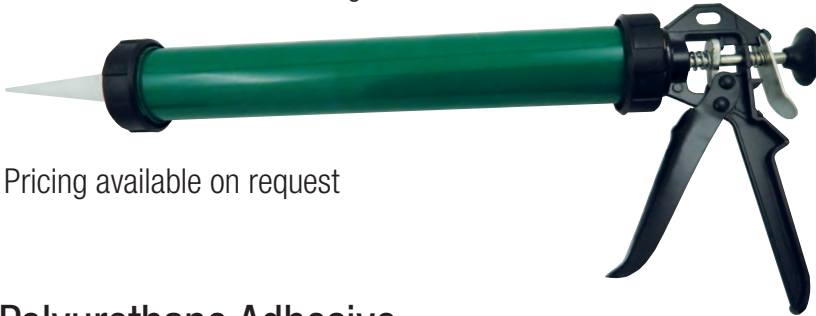

Pricing available on request

Polyurethane Adhesive

890100182KD



Pricing available on request

Vinyl Hazard Tape



UL-HZ2503 Hazard Tape

25mm x 3m roll of
photoluminescent
adhesive vinyl tape

Use this to highlight obstacles along
the escape route

Ecoglo Escape Route Products FAQs

Q *How much do they cost?*

A The cost varies as it can be dependent on several different factors, such as number of steps, length of pathway, whether or not you are already installing step nosing for example - a factor which may reduce your overall costs. In the majority of situations the cost is substantially less than the alternative option (electrical emergency lighting).

Q *Do they need electrical light installed near them?*

A No, they are designed to utilise the existing light in the building, be it daylight or electrical. Outdoors, daylight is sufficient to ensure they will work 24/7.

Q *How long do they last?*

A A minimum of 30 years when installed indoors before there would be any measurable change in performance, and 15 - 30 years outdoors.

Q *What maintenance is required?*

A Make sure they are cleaned of dust or dirt build up. Ecoglo recommends a 6-monthly check to meet the building's Compliance Schedule requirements, to enable annual sign-off for the Building's Warrant of Fitness (BWOF).

Q *Ecoglo's information states that specified features¹ be illuminated with a minimum charge of 20 lux continuously during occupancy of Risk Group C buildings² and 60 lux continuously during occupancy of Risk Group B buildings³.*

What if these illumination requirements aren't currently met?

A Ecoglo escape routes products are designed to work in most normal lighting situations. Ecoglo's professional engineer can, in many circumstances, design an alternative solution to meet F6. This is a free service. Contact Ecoglo (engineer@ecoglo.com) for details.

Q *Do the lights near the products need to be turned on before the building is occupied?*

A No. Ecoglo photoluminescent products will, in most situations, achieve full operational charge in well under 5 minutes because of residual charge left in them from previous use.

Q *What happens if there is a lights-out emergency in the first 5 minutes of occupation?*

A In most cases Ecoglo products will have sufficient residual charge from when there was light on them before, but even if the product has become fully discharged and someone enters a dark space and turns on a light, Ecoglo escape route products will meet the F6 brightness requirement for a longer evacuation time than the time since the light was turned on. By the time 5 minutes has elapsed the products will have the full 30 minutes charge required for Risk Group C buildings and the full 90 minutes required for Risk Group B buildings.

Q *How reliable are they?*

A They have no moving parts or components that will need replacing. As long as they are installed where there are normal indoor light levels, and they are kept reasonably clean, and not physically damaged, they will be visible in an emergency for the time required by F8 and F6 for at least 30 years.

Ecoglo Escape Route Products FAQs

Q *Where are they made?*

A They are designed and manufactured in Christchurch, using a unique process that was developed locally, over twenty years ago.

Q *Where can they be used?*

A Ecoglo escape route products can be used anywhere they can be sufficiently charged when someone may need to use them. Our products are in use throughout New Zealand and overseas in hospitals, educational facilities, apartment blocks, office blocks, hotels, retail spaces, factories, warehouses, theatres, sports stadiums and many other types of building. Contact Ecoglo for more details.

Q *Who can install them?*

A We recommend that a qualified building trades-person installs them in accordance with the Ecoglo installation instructions. The installer will need to complete the Ecoglo PS3 form (available on the website [www.ecoglo.co.nz] in the Technical section under Installation Instructions) to confirm that the installation has been carried out in accordance with Ecoglo instructions.

Q *What are their environmental credentials?*

A They are made in New Zealand in a factory that uses electricity (from a supplier committed to sustainable electricity production) as its only energy source. The factory creates no commercial liquid effluent, and negligible air emissions. The products have no replaceable parts which would need to be disposed of, and no cadmium or mercury. They normally don't require any electricity to be used to keep them charged. They have an extremely long life, and if for any reason they need to be disposed of, they can be included with other aluminium products for aluminium recycling.

Q *Can they be used outdoors?*

A Yes, our escape route products are designed to meet the rigours of long term outdoor exposure in our harsh Southern Hemisphere environment. No matter what the weather, the requirements of F6 are met 24/7 when installed outdoors.

1 Eg stairs, ramps, escape doors, handrails, changes in direction

2 Almost all buildings with less than 1000 occupants are Risk Group C

3 A building with over 1000 occupants and whose occupants are not required to remain in the building during an emergency

Risk Group B Buildings*

How to check if Ecoglo photoluminescent markings will meet F6 with an alternative solution

F6 requires 'specified features' to be made visible. Specified features include: Stairs and ramps, escape doors, handrails, changes in direction and obstructions. See the most recent Technical Justification for Ecoglo Markings document at www.ecoglo.co.nz for more details.

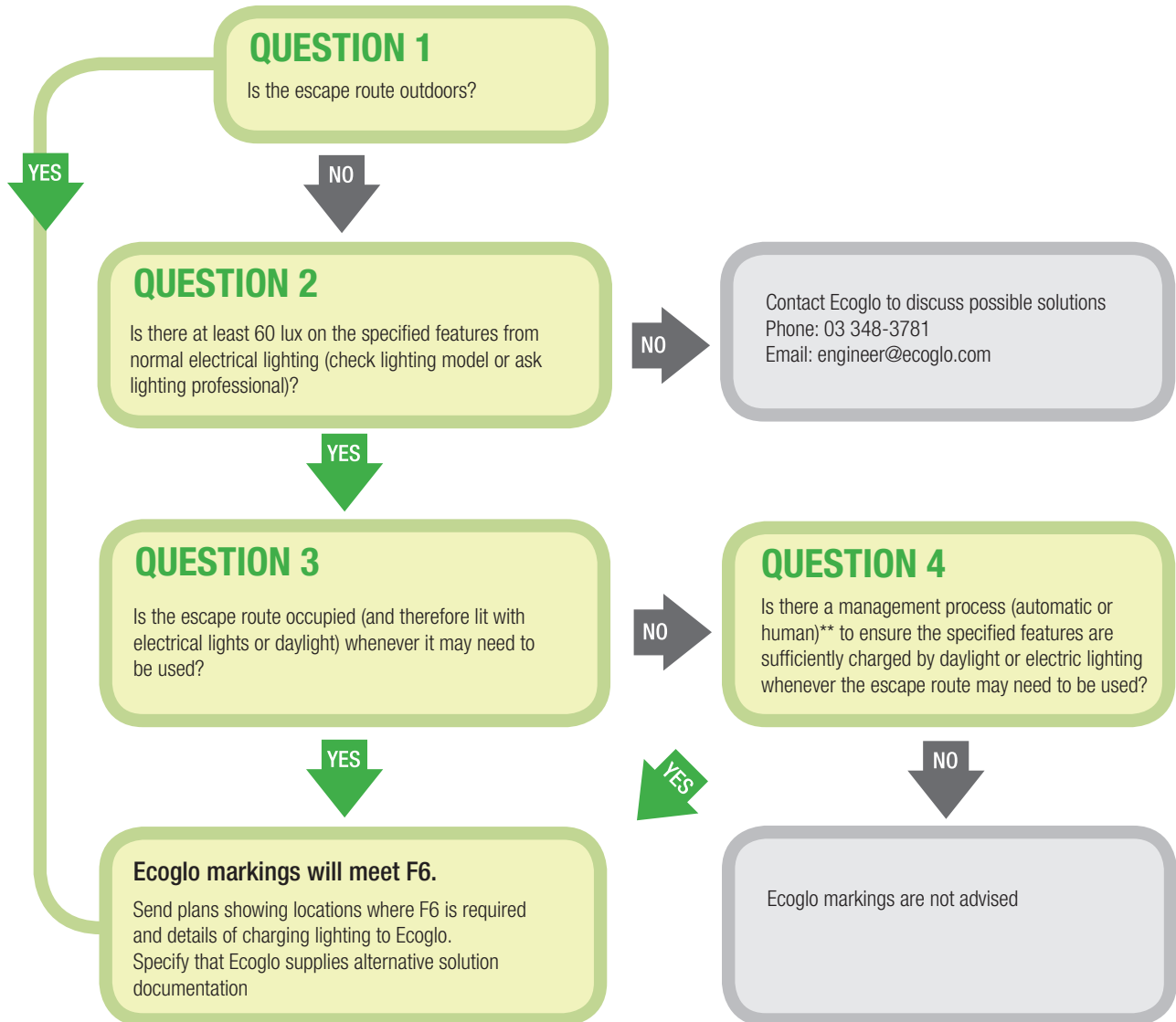

* NZBC F6 definition for Risk Group B: a building with an evacuation time between 30 minutes and 90 minutes, an occupant load over 1000 and whose occupants are not required to remain in the building during an emergency.

** Effective management processes include:

1. Light directly or indirectly from windows and skylights is >20 lux and the escape route will not be used later than 2.5 hours after sunset.
2. Lights will be switched on automatically by the building's security system whenever the building is able to be occupied.
3. Lights will be switched on manually by people occupying space that may need to use the escape route: warning signs will be placed by the light switches.
4. Smart sensors will allow the light levels to reduce to 10 lux while the space is unoccupied.
5. Circuits link lighting so that when lights are switched on in an occupied space all markings in all escape paths from the occupied space are lit.

Risk Group C Buildings*

How to check if Ecoglo photoluminescent markings will meet F6 with an alternative solution

F6 requires 'specified features' to be made visible. Specified features include: Stairs and ramps, escape doors, handrails, changes in direction and obstructions. See the most recent Technical Justification for Ecoglo Markings document at www.ecoglo.co.nz for more details.

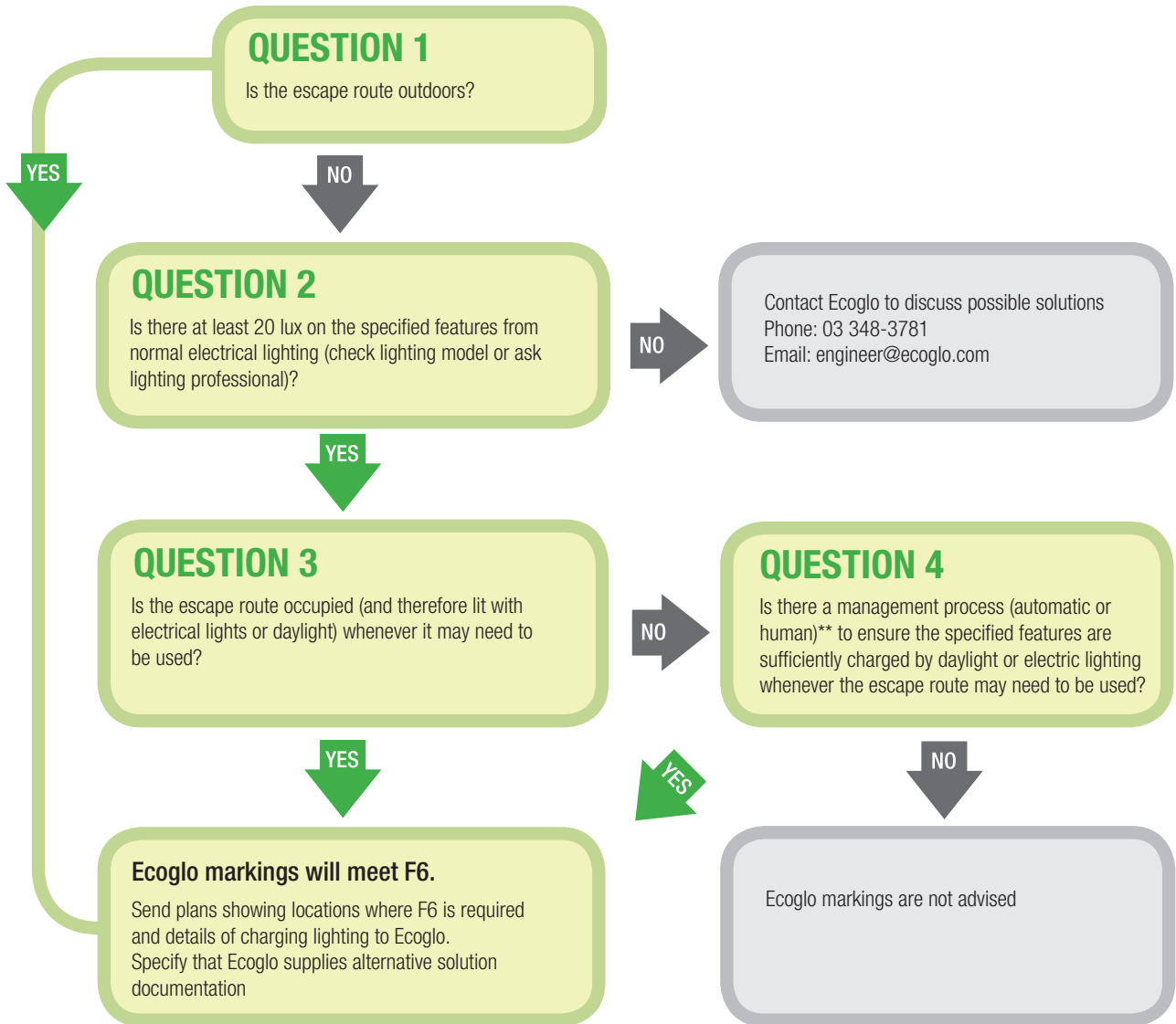

* NZBC F6 definition for Risk Group C: a building with an evacuation time of less than 30 minutes, an occupant load no more than 1000, and whose occupants are not to remain in the building during an emergency.

** Effective management processes include:

1. Light directly or indirectly from windows and skylights is >20 lux and the escape route will not be used later than 2.5 hours after sunset.
2. Lights will be switched on automatically by the building's security system whenever the building is able to be occupied.
3. Lights will be switched on manually by people occupying a space that may need to use the escape route: warning signs will be placed by the light switches.
4. Smart sensors will allow the light levels to reduce to 10 lux while the space is unoccupied.
5. Circuits link lighting so that when lights are switched on in an occupied space all markings in all escape paths from the occupied space are lit.

F6 Maintenance Checking

Recommended Maintenance Checking Procedure for Ecoglo Escape Route Products:

Monthly Maintenance Check *(to be carried out by the Owner or their appointed agent)* COMPLETED

- All products are still configured as at installation and there is no material damage to any of the products.
- All products are clean from general dust build up and any other specific obscuring deposits.
- All products are clearly visible and have not been covered up by carpet or other materials.
- All products mark a clear path and have not been obstructed by physical hazards such as trolleys, machinery, partitions, etc.
- All products can be used to provide clear escape path marking and there has been no change to the configuration of the building which renders the escape path unusable.
- All lights within 4m of Ecoglo markings have been checked that the positions have not altered from design.
- All lights within 4m of Ecoglo markings are in working order and clean.
- All automated lighting control systems are operational as per design

Annual Inspection *(to be carried out by an IQP)* COMPLETED

- All products are still configured as at installation and there is no material damage to any of the products.
- All products are clean from general dust build up and any other specific obscuring deposits.
- All products are clearly visible and have not been covered up by carpet or other materials.
- All products mark a clear path and have not been obstructed by physical hazards such as trolleys, machinery, partitions, etc.
- All products can be used to provide clear escape path marking and there has been no change to the configuration of the building which renders the escape path unusable.
- All lights within 4m of Ecoglo markings have been checked that the positions have not altered from design.
- All lights within 4m of Ecoglo markings are in working order and clean.
- All automated lighting control systems are operational as per design

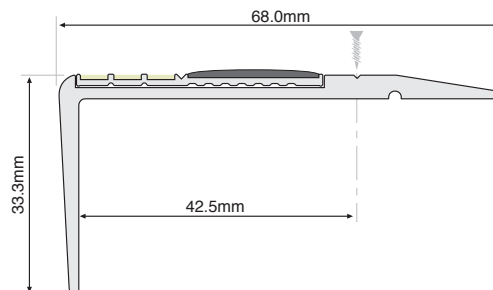
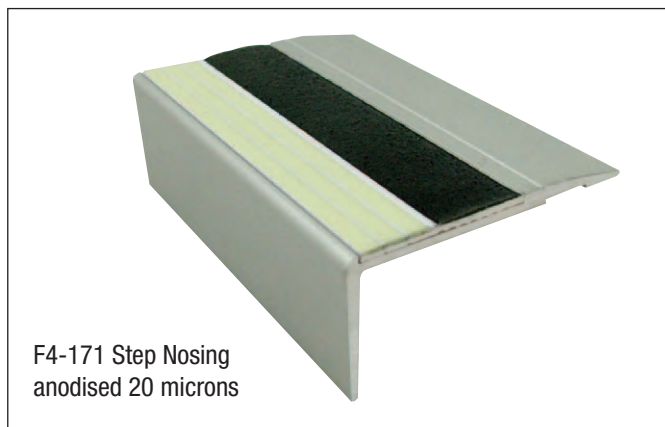

COMPOSITION

Step Nosing profile consisting of 6060T5 aluminium extrusion, anodized (natural/silver colour) to 20 microns thickness.

Ecoglo E2-071 Step Edge Contrast is adhesively fixed into the extrusion. The high visibility E2-071 is manufactured from extruded 6060T5 aluminium section. Silicon Carbide anti-slip materials and custom made photoluminescent pigment are embedded in thermoset polyester carriers to integrally bond the active ingredients into the aluminium following curing at high temperature. The photoluminescent area is also recessed into protective channels.

INSTALLATION

The F4-171 Step Nosing can be used on a range of substrates including concrete, timber, tiles, vinyl, steel and checker plate. Uni clamp assemblies can be used for installation onto steel mesh steps.

Installation is a simple process using fixers (supplied) and polyurethane adhesive. It can also be fitted over steps with an industrial or commercial style carpet with no underlay. For thicker carpet, cut the carpet away and use a packer.

Maximum recommended length for outdoor installation is 1500mm.

Consult Installation Instructions on website for full details and surface preparation.

The F4-171 Step Nosing is designed to ensure visibility of steps in escape routes to meet NZBC Clause F6 “Visibility in Escape Routes”. The Step Nosing will be effective in all light conditions including during failure of the main lighting.

PERFORMANCE

Independently tested in accordance with UL 1994 for 10 metre visibility to meet NZBC Clause F6.

Risk Group C Building

30 minutes visibility
Minimum charging illuminance of 20 lux continuously during occupancy.

Risk Group B Building

90 minutes visibility
Minimum charging illuminance of 60 lux continuously during occupancy.

Outdoor or daylit installations will absorb enough natural light to be visible throughout the longest winter night.

The Step Nosing is suitable for use indoors and outdoors. The anti-slip material provides all weather protection from slips and falls.

Anti-Slip Properties - AS/NZS 4586-2004 Classification:

Dry: F Wet: V Ramp: R12. AS4586-2013 Classification: P5

UV Resistance - Loss of luminance after 1000 hrs ASTM G-155 Cycle 1 exposure: <10%: Pass

Salt Spray Resistance - ASTM B117: Pass

Washability - ASTM D4828: Pass

Rate of Burning - ASTM D635: Pass

Surface Flammability - ASTM E162: Pass

Toxicity - Bombardier Toxic Gas Generation Test SMP800-C: Pass

Radioactivity - ASTM D3648: Pass

SUPPLY

The products are available in lengths of 100mm increments from 600mm to 1500mm to comply with IBC recommendations to mark the escape path on the front edge of the step to within 50mm of the wall or the side of the step.

Custom lengths can also be fabricated on site or in the factory from 2.45 metre or 3.06 metre lengths.

PRODUCT CODE	PRODUCT DESCRIPTION	PRODUCT LENGTH
F4-171-600	Step Nosing 68mm x 33mm	600mm
F4-171-700	Step Nosing 68mm x 33mm	700mm
F4-171-800	Step Nosing 68mm x 33mm	800mm
F4-171-900	Step Nosing 68mm x 33mm	900mm
F4-171-1000	Step Nosing 68mm x 33mm	1000mm
F4-171-1100	Step Nosing 68mm x 33mm	1100mm
F4-171-1200	Step Nosing 68mm x 33mm	1200mm
F4-171-1300	Step Nosing 68mm x 33mm	1300mm
F4-171-1400	Step Nosing 68mm x 33mm	1400mm
F4-171-1500	Step Nosing 68mm x 33mm	1500mm

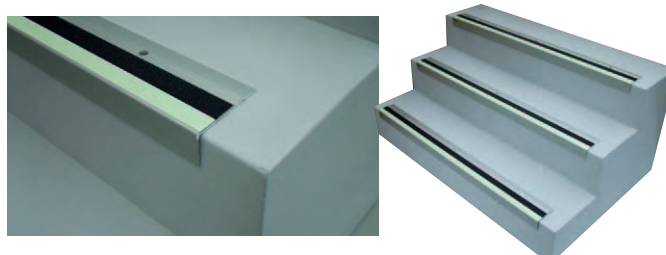

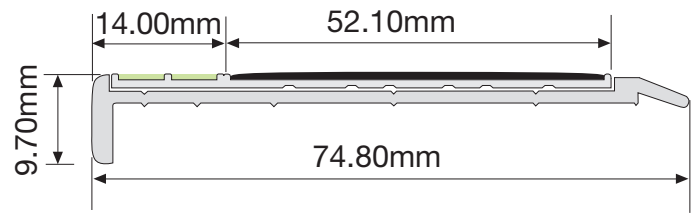
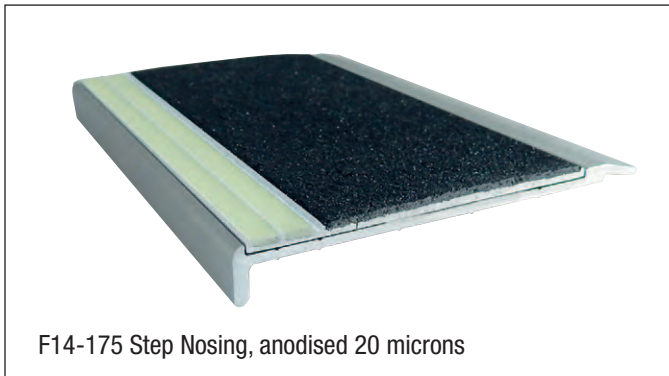

SUPPLY

The products are available in lengths of 100mm increments from 600mm to 1500mm to comply with IBC recommendations to mark the escape path on the front edge of the step to within 50mm of the wall or the side of the step. Custom lengths can also be fabricated on site or in the factory from 2.45 metre or 3.06 metre lengths.

COMPOSITION

Step Nosing profile consisting of 6060T5 aluminium extrusion, anodized (natural/silver colour) to 20 microns thickness.

Ecoglo E14-075 Step Edge Contrast is adhesively fixed into the extrusion. The high visibility E14-075 is manufactured from extruded 6060T5 aluminium section. Silicon Carbide anti-slip materials and custom made photoluminescent pigment are embedded in thermoset polyester carriers to integrally bond the active ingredients into the aluminium following curing at high temperature. The photoluminescent area is also recessed into protective channels.

INSTALLATION

The F14-175 Step Nosing can be used on a range of substrates including concrete, timber, tiles, vinyl, steel and checker plate. Uni clamp assemblies can be used for installation onto steel mesh steps. Installation is a two step process using fixers (supplied) and polyurethane adhesive. It can also be fitted over steps with an industrial or commercial style carpet with no underlay. For thicker carpet, cut the carpet away and use a packer.

Maximum recommended length for outdoor installation is 1500mm.

Consult Installation Instructions on website for full details and surface preparation.

The F14-175 Step Nosing is designed to ensure visibility of steps in escape routes to meet NZBC Clause F6 “Visibility in Escape Routes”. The Step Nosing will be effective in all light conditions including during failure of the main lighting.

PERFORMANCE

Independently tested in accordance with UL 1994 for 10 metre visibility to meet NZBC Clause F6.

Risk Group C Building

30 minutes visibility

Minimum charging illuminance of 20 lux continuously during occupancy.

Risk Group B Building

90 minutes visibility

Minimum charging illuminance of 60 lux continuously during occupancy.

Outdoor or daylight installations will absorb enough natural light to be visible throughout the longest winter night.

The Step Nosing is suitable for use indoors and outdoors. The anti-slip material provides all weather protection from slips and falls.

Anti-Slip Properties - AS/NZS 4586-2004 Classification:

Dry: F Wet: V Ramp: R12. AS4586-2013 Classification: P5

UV Resistance - Loss of luminance after 1000 hrs ASTM G-155 Cycle 1 exposure: <10%: Pass

Salt Spray Resistance - ASTM B117: Pass

Washability - ASTM D4828: Pass

Rate of Burning - ASTM D635: Pass

Surface Flammability - ASTM E162: Pass

Toxicity - Bombardier Toxic Gas Generation Test SMP800-C: Pass

Radioactivity - ASTM D3648: Pass

Note: Custom colours are available to meet AS1428.1 luminance contrast for any surface colour

PRODUCT CODE	PRODUCT DESCRIPTION	PRODUCT LENGTH
F14-175-600	Step Nosing 75mm x 10mm	600mm
F14-175-700	Step Nosing 75mm x 10mm	700mm
F14-175-800	Step Nosing 75mm x 10mm	800mm
F14-175-900	Step Nosing 75mm x 10mm	900mm
F14-175-1000	Step Nosing 75mm x 10mm	1000mm
F14-175-1100	Step Nosing 75mm x 10mm	1100mm
F14-175-1200	Step Nosing 75mm x 10mm	1200mm
F14-175-1300	Step Nosing 75mm x 10mm	1300mm
F14-175-1400	Step Nosing 75mm x 10mm	1400mm
F14-175-1500	Step Nosing 75mm x 10mm	1500mm

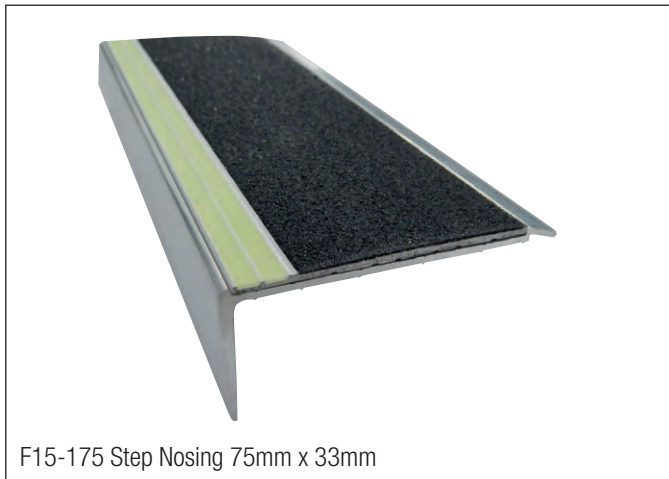

F15-175 Step Nosing 75mm x 33mm

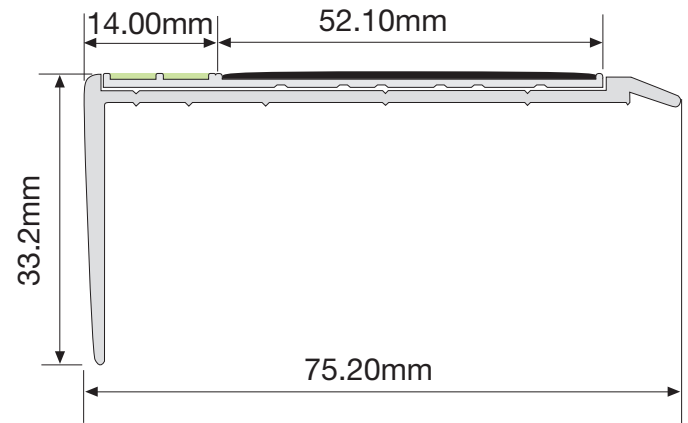

The F15-175 Step Nosing is designed to ensure visibility of steps in escape routes to meet NZBC Clause F6 “Visibility in Escape Routes”. The Step Nosing will be effective in all light conditions including during failure of the main lighting.

PERFORMANCE

Independently tested in accordance with UL 1994 for 10 metre visibility to meet NZBC Clause F6.

Risk Group C Building

30 minutes visibility

Minimum charging illuminance of 20 lux continuously during occupancy.

Risk Group B Building

90 minutes visibility

Minimum charging illuminance of 60 lux continuously during occupancy.

Outdoor or daylight installations will absorb enough natural light to be visible throughout the longest winter night.

The Step Nosing is suitable for use indoors and outdoors. The anti-slip material provides all weather protection from slips and falls.

Anti-slip Properties –

AS/NZS 4586-2004 Classification: Dry: F Wet: V Ramp: R13

AS 4586-2013 Classification: P5

UV Resistance - Loss of luminance after 1000 hrs ASTM G-155

Cycle 1 exposure: <10%

Salt Spray Resistance – ASTM B117: Pass

Washability – ASTM D4828: Pass

Rate of Burning – ASTM D635: Pass

Surface Flammability - ASTM E162: Pass

Toxicity - Bombardier Toxic Gas Generation Test SMP800-C: Pass

Radioactivity - ASTM D3648: Pass

SUPPLY

The products are available in 100mm increments from 600mm to 1500mm to comply with IBC recommendations to mark the escape path on the front edge of the step to within 50mm of the wall or the side of the step.

COMPOSITION

The F15-175 Step Nosing profile consists of 6063T6 aluminium extrusion, anodized (natural/silver colour) to 20 microns thickness.

Ecoglo E14-075 Step Edge Contrast is adhesively fixed into the extrusion. The high visibility E14-075 is manufactured from extruded 60605T aluminium section. Silicon Carbide anti-slip materials and custom made photoluminescent pigment are embedded in thermoset polyester carriers to integrally bond the active ingredients into the aluminium following curing at high temperature. The photoluminescent area is also recessed into protective channels.

INSTALLATION

The F15-175 Step Nosing can be used on a range of substrates including concrete, timber, tiles, vinyl, steel and checker plate. Uni clamp assemblies can be used for installation onto steel mesh steps. It can also be fitted over steps with an industrial or commercial style carpet with no underlay. For thicker carpet, cut the carpet away and use a packer.

Maximum recommended length for outdoor installation is 1500mm.

Installation is a simple process using fixers (supplied) and polyurethane adhesive.

Consult Installation Instructions on website for full details and surface preparation.

PRODUCT CODE	PRODUCT DESCRIPTION	PRODUCT LENGTH
F15-175-600	Step Nosing 75mm x 33mm	600mm
F15-175-700	Step Nosing 75mm x 33mm	700mm
F15-175-800	Step Nosing 75mm x 33mm	800mm
F15-175-900	Step Nosing 75mm x 33mm	900mm
F15-175-1000	Step Nosing 75mm x 33mm	1000mm
F15-175-1100	Step Nosing 75mm x 33mm	1100mm
F15-175-1200	Step Nosing 75mm x 33mm	1200mm
F15-175-1300	Step Nosing 75mm x 33mm	1300mm
F15-175-1400	Step Nosing 75mm x 33mm	1400mm
F15-175-1500	Step Nosing 75mm x 33mm	1500mm

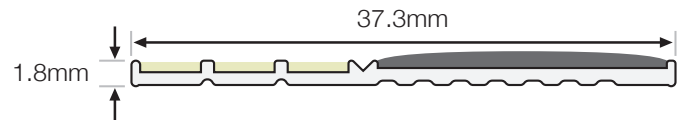
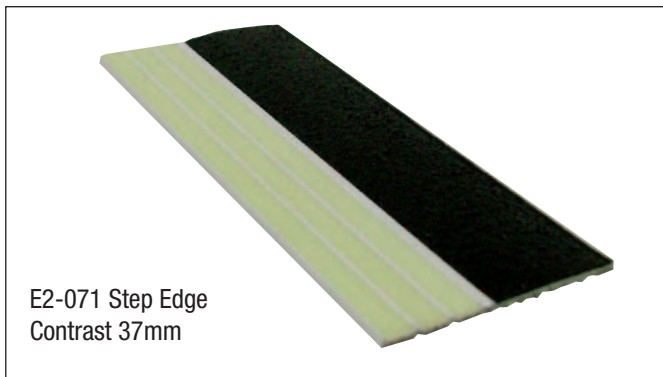

COMPOSITION

Ecoglo E2-071 Step Edge Contrast is manufactured from extruded 6060T5 aluminium section. Silicon Carbide anti-slip materials and custom made photoluminescent pigment are embedded in thermoset polyester carriers to integrally bond the active ingredients into the aluminium following curing at high temperature. The photoluminescent area is also recessed into protective channels.

INSTALLATION

Indoors the E2-071 Step Edge Contrast can be surface mounted on all smooth surfaces. Outdoors the E2-071 Step Edge Contrast can be surface mounted onto concrete.

Installation is a simple process using polyurethane adhesive.

Maximum recommended length for outdoor installation is 1500mm.

Consult Installation Instructions on website for full details and surface preparation.

Screws can be used if adhesion is difficult.
(See order codes below for the product that best suits).

The E2-071 Step Edge Contrast is designed to ensure visibility of steps in escape routes to meet NZBC Clause F6 “Visibility in Escape Routes”. The Step Edge contrast will be effective in all light conditions including during failure of the main lighting.

PERFORMANCE

Independently tested in accordance with UL 1994 for 10 metre visibility to meet NZBC Clause F6.

Risk Group C Building

30 minutes visibility
Minimum charging illuminance of 20 lux continuously during occupancy.

Risk Group B Building

90 minutes visibility
Minimum charging illuminance of 60 lux continuously during occupancy.

Outdoor or daylight installations will absorb enough natural light to be visible throughout the longest winter night.

The Step Edge Contrast is suitable for use indoors and outdoors. The anti-slip material provides all weather protection from slips and falls.

Anti-Slip Properties - AS/NZS 4586-2004 Classification:

Dry: F Wet: V Ramp: R12. AS4586-2013 Classification: P5

UV Resistance - Loss of luminance after 1000 hrs ASTM G-155 Cycle 1 exposure: <10%: Pass

Salt Spray Resistance - ASTM B117: Pass

Washability - ASTM D4828: Pass

Rate of Burning - ASTM D635: Pass

Surface Flammability - ASTM E162: Pass

Toxicity - Bombardier Toxic Gas Generation Test SMP800-C: Pass

Radioactivity - ASTM D3648: Pass

SUPPLY

The products are available in lengths of 100mm increments from 600mm to 1500mm to comply with IBC recommendations to mark the escape path on the front edge of the step to within 50mm of the wall or the side of the step. Custom lengths can also be fabricated on site or in the factory from 2.45 metre or 3.06 metre lengths.

E2-071 For polyurethane adhesive fixing
E2-071P Punched for screw fixing

PRODUCT CODE	PRODUCT DESCRIPTION	PRODUCT LENGTH
E2-071-600	Step Edge Contrast 37mm	600mm
E2-071-700	Step Edge Contrast 37mm	700mm
E2-071-800	Step Edge Contrast 37mm	800mm
E2-071-900	Step Edge Contrast 37mm	900mm
E2-071-1000	Step Edge Contrast 37mm	1000mm
E2-071-1100	Step Edge Contrast 37mm	1100mm
E2-071-1200	Step Edge Contrast 37mm	1200mm
E2-071-1300	Step Edge Contrast 37mm	1300mm
E2-071-1400	Step Edge Contrast 37mm	1400mm
E2-071-1500	Step Edge Contrast 37mm	1500mm

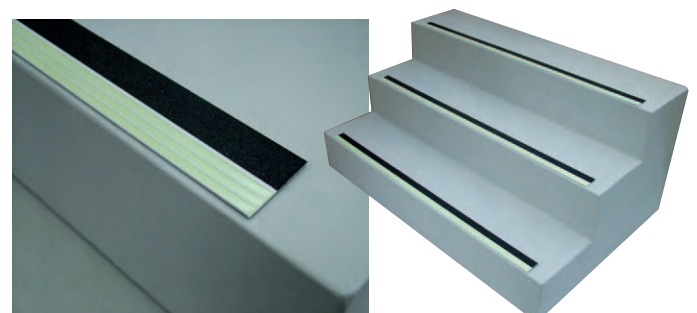

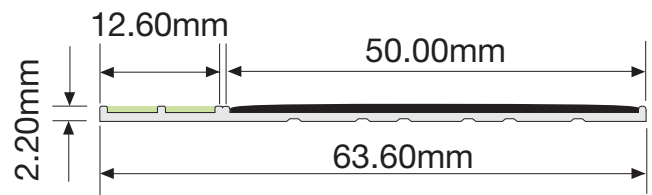
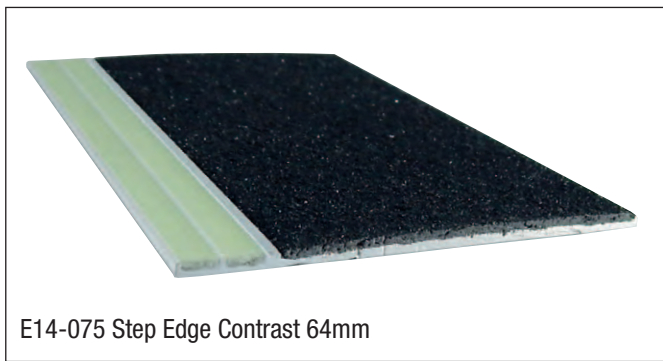

The E14-075 Step Edge Contrast is designed to ensure visibility of steps in escape routes to meet NZBC Clause F6 “Visibility in Escape Routes”. The Step Edge contrast will be effective in all light conditions including during failure of the main lighting.

PERFORMANCE

Independently tested in accordance with UL 1994 for 10 metre visibility to meet NZBC Clause F6.

Risk Group C Building

30 minutes visibility
Minimum charging illuminance of 20 lux continuously during occupancy.

Risk Group B Building

90 minutes visibility
Minimum charging illuminance of 60 lux continuously during occupancy.

Outdoor or daylight installations will absorb enough natural light to be visible throughout the longest winter night.

The Step Edge Contrast is suitable for use indoors and outdoors. The anti-slip material provides all weather protection from slips and falls.

Anti-Slip Properties - AS/NZS 4586-2004 Classification:

Dry: F Wet: V Ramp: R12. AS4586-2013 Classification: P5

UV Resistance - Loss of luminance after 1000 hrs ASTM G-155 Cycle 1 exposure: <10%: Pass

Salt Spray Resistance - ASTM B117: Pass

Washability - ASTM D4828: Pass

Rate of Burning - ASTM D635: Pass

Surface Flammability - ASTM E162: Pass

Toxicity - Bombardier Toxic Gas Generation Test SMP800-C: Pass

Radioactivity - ASTM D3648: Pass

Note: Custom colours are available to meet AS1428.1 luminance contrast for any surface colour

SUPPLY

The products are available in lengths of 100mm increments from 600mm to 1500mm to comply with IBC recommendations to mark the escape path on the front edge of the step to within 50mm of the wall or the side of the step. Custom lengths can also be fabricated on site or in the factory from 2.45 metre or 3.06 metre lengths.

COMPOSITION

Ecoglo E14-075 Step Edge Contrast is manufactured from extruded 6060T5 aluminium section. Silicon Carbide anti-slip materials and custom made photoluminescent pigment are embedded in thermoset polyester carriers to integrally bond the active ingredients into the aluminium following curing at high temperature. The photoluminescent area is also recessed into protective channels.

INSTALLATION

Indoors the E14-075 Step Edge Contrast can be surface mounted on all smooth surfaces. Outdoors the E14-075 Step Edge Contrast can be surface mounted onto concrete.

Installation is a simple process using polyurethane adhesive. Maximum recommended length for outdoor installation is 1500mm.

Consult Installation Instructions on website for full details and surface preparation.

Screws can be used if adhesion is difficult.
(See order codes below for the product that best suits).

E14-075 For polyurethane adhesive fixing
E14-075P Punched for screw fixing

PRODUCT CODE	PRODUCT DESCRIPTION	PRODUCT LENGTH
E14-075-600	Step Edge Contrast 64mm	600mm
E14-075-700	Step Edge Contrast 64mm	700mm
E14-075-800	Step Edge Contrast 64mm	800mm
E14-075-900	Step Edge Contrast 64mm	900mm
E14-075-1000	Step Edge Contrast 64mm	1000mm
E14-075-1100	Step Edge Contrast 64mm	1100mm
E14-075-1200	Step Edge Contrast 64mm	1200mm
E14-075-1300	Step Edge Contrast 64mm	1300mm
E14-075-1400	Step Edge Contrast 64mm	1400mm
E14-075-1500	Step Edge Contrast 64mm	1500mm

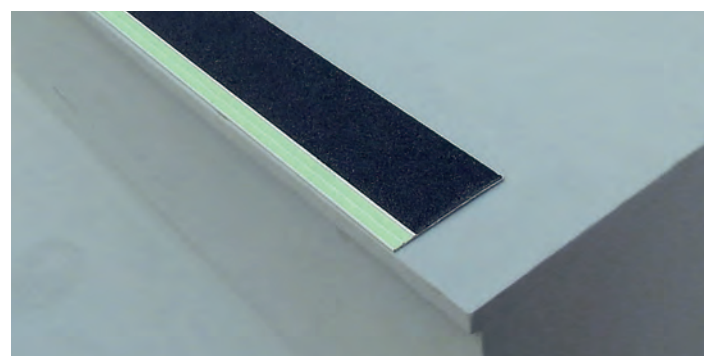

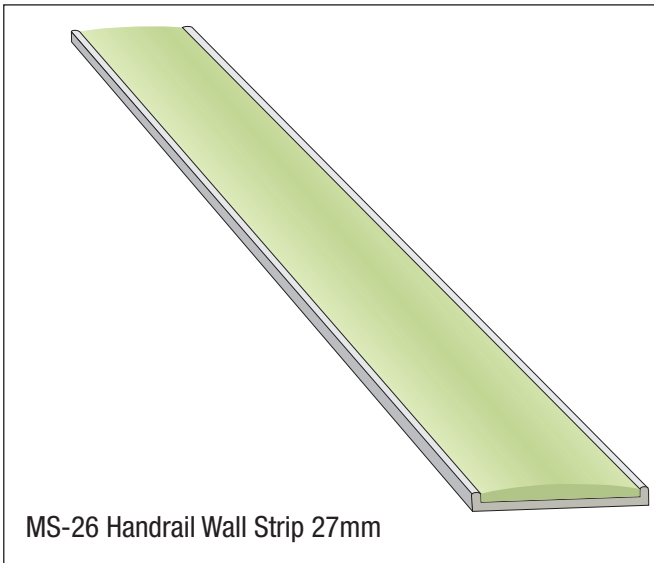

MS-26 Handrail Wall Strip 27mm

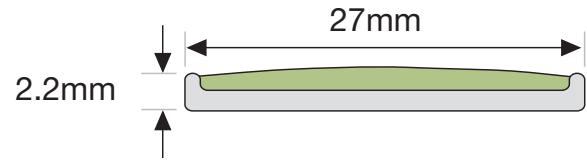

Risk Group B Building

90 minutes visibility

Minimum charging illuminance of 60 lux continuously during occupancy.

Outdoor or daylit installations will absorb enough natural light to be visible throughout the longest winter night.

The handrail strip is suitable for use indoors and outdoors.

UV Resistance - Loss of luminance after 1000 hrs ASTM G-155

Cycle 1 exposure: <10%: Pass

Salt Spray Resistance - ASTM B117: Pass

Washability - ASTM D4828: Pass

Rate of Burning - ASTM D635: Pass

Surface Flammability - ASTM E162: Pass

Toxicity - Bombardier Toxic Gas Generation Test SMP800-C: Pass

Radioactivity - ASTM D3648: Pass

The MS-26 Handrail Wall Strip is designed to ensure visibility of handrails in escape routes to meet NZBC Clause F6 “Visibility in Escape Routes”. The guidance strip is fitted to the wall above the handrail and will be effective in all light conditions including during failure of the main lighting.

PERFORMANCE

Independently tested in accordance with UL1994 for 10 metre visibility to meet NZBC Clause F6.

Risk Group C Building

30 minutes visibility

Minimum charging illuminance of 20 lux continuously during occupancy.

SUPPLY

The products are available in 1 metre lengths.

COMPOSITION

Ecoglo MS-26 Handrail Wall Strip is manufactured from extruded 6060T5 aluminium section. Custom made photoluminescent pigments are embedded in thermoset polyester carriers to integrally bond the active ingredients into the aluminium following curing at high temperature.

INSTALLATION

Installation is a simple process using pre-fitted release tape.

Consult Installation Instructions on website for full details and surface preparation.

Screws or rivets can be used if adhesion is difficult.

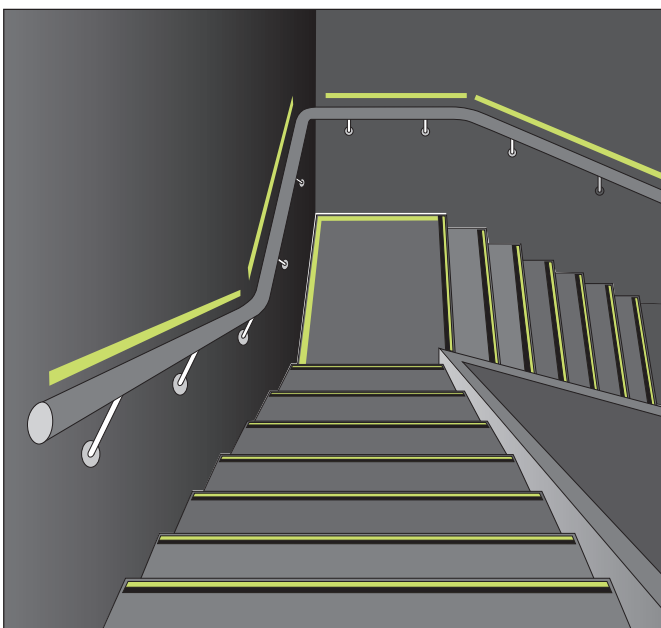

MS-26T-1000 Release tape pre-fitted

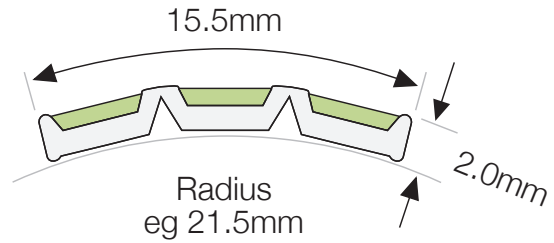

Outdoor or daylight installations will absorb enough natural light to be visible throughout the longest winter night.

The Handrail Marker is suitable for use indoors and outdoors.

The H3-001 Handrail Marker is designed to ensure visibility of handrails in escape routes to meet NZBC Clause F6 'Visibility in Escape Routes'. The H3-001 Handrail Marker will be effective in all light conditions including during failure of the main lighting.

PERFORMANCE

Independently tested in accordance with UL1994 for 10 metre visibility to meet NZBC Clause F6.

Risk Group C Building

30 minutes visibility

Minimum charging illuminance of 20 lux continuously during occupancy.

Risk Group B Building

90 minutes visibility

Minimum charging illuminance of 60 lux continuously during occupancy.

UV Resistance - Loss of luminance after 1000 hrs ASTM G-155 Cycle 1 exposure: <10%: Pass

Salt Spray Resistance - ASTM B117: Pass

Washability - ASTM D4828: Pass

Rate of Burning - ASTM D635: Pass

Surface Flammability - ASTM E162: Pass

Toxicity - Bombardier Toxic Gas Generation Test SMP800-C: Pass

Radioactivity - ASTM D3648: Pass

SUPPLY

The products are available in 1 metre and 1.5 metre lengths.

PRODUCT CODE	PRODUCT DESCRIPTION	PRODUCT LENGTH
H3001T-1000	Handrail Marker 16mm	1000mm
H3001T-1500	Handrail Marker 16mm	1500mm

COMPOSITION

Ecoglo H3-001 Handrail Marker is manufactured from extruded 6060T5 aluminium section. Custom made photoluminescent pigment are embedded in thermoset polyester carriers to integrally bond the active ingredients into the aluminium following curing at high temperature. The photoluminescent area is also recessed into protective channels.

INSTALLATION

Installation is a simple process using the pre-fitted release tape.

Consult Installation Instructions on website for full details and surface preparation.

Screws or rivets can be used if adhesion is difficult.

H3-001T-1000 Release tape pre-fitted
H3-001T-1500 Release tape pre-fitted



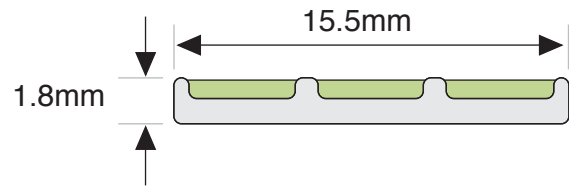

Outdoor or daylight installations will absorb enough natural light to be visible throughout the longest winter night.

The Guidance Strip is suitable for use indoors and outdoors.

UV Resistance - Loss of luminance after 1000 hrs ASTM G-155

Cycle 1 exposure: <10%: Pass

Salt Spray Resistance - ASTM B117: Pass

Washability - ASTM D4828: Pass

Rate of Burning - ASTM D635: Pass

Surface Flammability - ASTM E162: Pass

Toxicity - Bombardier Toxic Gas Generation Test SMP800-C: Pass

Radioactivity - ASTM D3648: Pass

The G3-001 Guidance Strip is designed to ensure visibility of handrails, pathways (including ramps and corridors) and doorways in escape routes to meet NZBC Clause F6 “Visibility in Escape Routes”. The Guidance Strip will be effective in all light conditions including during failure of the main lighting.

PERFORMANCE

Independently tested in accordance with UL1994 for 10 metre visibility to meet NZBC Clause F6.

Risk Group C Building

30 minutes visibility

Minimum charging illuminance of 20 lux continuously during occupancy.

Risk Group B Building

90 minutes visibility

Minimum charging illuminance of 60 lux continuously during occupancy.

SUPPLY

The products are available in 1 metre and 1.5 metre lengths.

COMPOSITION

Ecoglo G3-001 Guidance Strip is manufactured from extruded 6060T5 aluminium section. Custom made photoluminescent pigments are embedded in thermoset polyester carriers to integrally bond the active ingredients into the aluminium following curing at high temperature. The photoluminescent area is also recessed into protective channels.

INSTALLATION

Installation is a simple process using polyurethane adhesive, fixers (screws) or pre-fitted release tape.

Consult Installation Instructions on website for full details and surface preparation.

Fixers (screws) or release tape can be used if adhesion is difficult. (See order codes below for the product that best suits).



G3-001-1000 For polyurethane adhesive fixing

G3-001P-1000 Punched for screw fixing

G3-001T-1000 Release tape pre-fitted

G3-001T-1500 Release tape pre-fitted

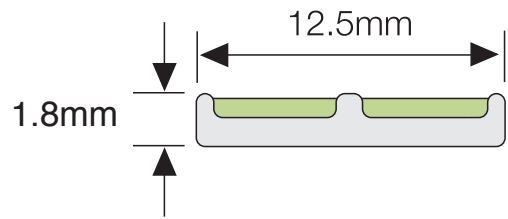
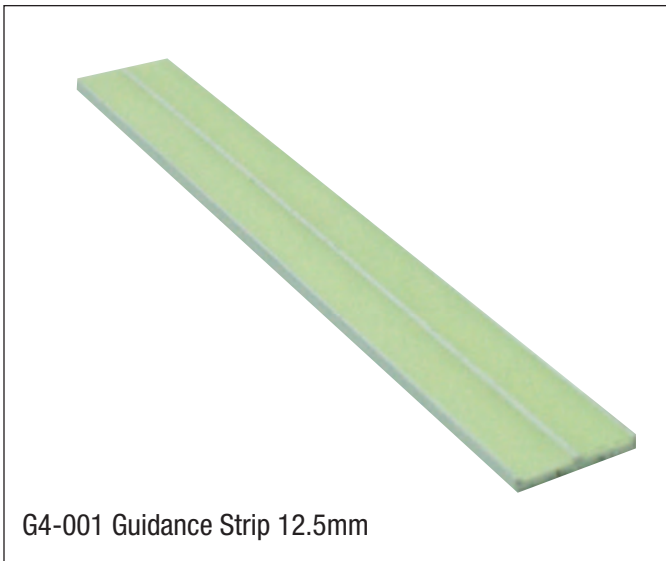

Outdoor or daylit installations will absorb enough natural light to be visible throughout the longest winter night.

The Guidance Strip is suitable for use indoors and outdoors.

UV Resistance - Loss of luminance after 1000 hrs ASTM G-155 Cycle 1 exposure: <10%: Pass

Salt Spray Resistance - ASTM B117: Pass

Washability - ASTM D4828: Pass

Rate of Burning - ASTM D635: Pass

Surface Flammability - ASTM E162: Pass

Toxicity - Bombardier Toxic Gas Generation Test SMP800-C: Pass

Radioactivity - ASTM D3648: Pass

SUPPLY

The products are available in 1 metre lengths.

COMPOSITION

Ecoglo G4-001 Guidance Strip is manufactured from extruded 6060T5 aluminium section. Custom made photoluminescent pigments are embedded in thermoset polyester carriers to integrally bond the active ingredients into the aluminium following curing at high temperature. The photoluminescent area is also recessed into protective channels.

INSTALLATION

Installation is a simple process using polyurethane adhesive, or pre-fitted release tape.

Consult Installation Instructions on website for full details and surface preparation.

(See order codes below for the product that best suits).

The G4-001 Guidance Strip is designed to ensure visibility of handrails, pathways (including ramps and corridors) and doorways in escape routes to meet NZBC Clause F6 “Visibility in Escape Routes”. The Guidance Strip will be effective in all light conditions including during failure of the main lighting.

PERFORMANCE

Independently tested in accordance with UL1994 for 10 metre visibility to meet NZBC Clause F6.

Risk Group C Building

30 minutes visibility

Minimum charging illuminance of 20 lux continuously during occupancy.

Risk Group B Building

90 minutes visibility

Minimum charging illuminance of 60 lux continuously during occupancy.



G4-001-1000 For polyurethane adhesive fixing
G4-001T-1000 Release tape pre-fitted

2018 V1

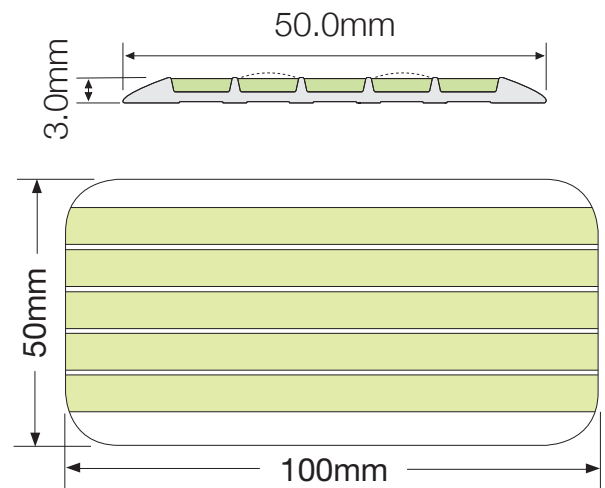

The G7-100 Solaris is designed to ensure visibility of pathways in escape routes to meet NZBC Clause F6 ‘Visibility in Escape Routes’. The G7-100 Solaris will be effective in all light conditions including during failure of the main lighting.

PERFORMANCE

Minimum frequency of 1 marker per metre meets the requirements of UL 1994 6.1.2b.

Risk Group C Building

30 minutes visibility
Minimum charging illuminance of 20 lux continuously during occupancy.

Risk Group B Building

90 minutes visibility
Minimum charging illuminance of 60 lux continuously during occupancy.

Outdoor or daylight installations will absorb enough natural light to be visible throughout the longest winter night.

The G7-100 Solaris is suitable for use indoors and outdoors.



UV Resistance - Loss of luminance after 1000 hrs ASTM G-155 Cycle 1 exposure: <10%: Pass
Salt Spray Resistance - ASTM B117: Pass
Washability - ASTM D4828: Pass
Rate of Burning - ASTM D635: Pass
Surface Flammability - ASTM E162: Pass
Toxicity - Bombardier Toxic Gas Generation Test SMP800-C: Pass
Radioactivity - ASTM D3648: Pass

SUPPLY

The product is available in a pack of 10 x 100mm pieces.

COMPOSITION

Ecoglo G7-100 Solaris is manufactured from extruded 6060T5 aluminium section. Custom made photoluminescent pigment is embedded in thermoset polyester carriers to integrally bond the active ingredients into the aluminium following curing at high temperature. The photoluminescent area is also recessed into protective channels.

INSTALLATION

Installation is a simple process using polyurethane adhesive, screws or pre-fitted release tape.

Consult Installation Instructions on website for full details and surface preparation.

Fixers (screws) or release tape can be used if adhesion is difficult. (See order codes below for the product that best suits).

G7-100 For polyurethane adhesive fixing
G7P-100 Punched for screw fixing
G7T-100 Release tape pre-fitted

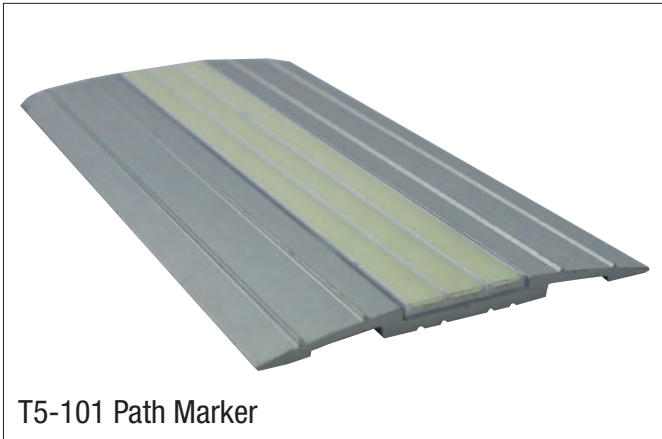

T5-101 Path Marker

The T5-101 Path Marker is designed to ensure visibility of pathways in escape routes to meet NZBC Clause F6 'Visibility in Escape Routes'. The Path Marker will be effective in all light conditions including during failure of the main lighting.

PERFORMANCE

Independently tested in accordance with UL1994 for 10 metre visibility to meet NZBC Clause F6.

Risk Group C Building

30 minutes visibility
Minimum charging illuminance of 20 lux continuously during occupancy.

Risk Group B Building

90 minutes visibility
Minimum charging illuminance of 60 lux continuously during occupancy.

Outdoor or daylit installations will absorb enough natural light to be visible throughout the longest winter night.

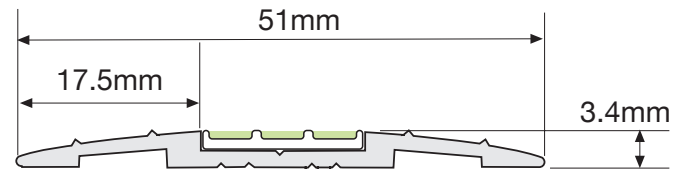

The Path Marker is suitable for use indoors and outdoors.

UV Resistance - Loss of luminance after 1000 hrs ASTM G-155

Cycle 1 exposure: <10%: Pass

Salt Spray Resistance - ASTM B117: Pass

Washability - ASTM D4828: Pass

Rate of Burning - ASTM D635: Pass

Surface Flammability - ASTM E162: Pass

Toxicity - Bombardier Toxic Gas Generation Test SMP800-C: Pass

Radioactivity - ASTM D3648: Pass

SUPPLY

The product is available in 1 metre lengths.

COMPOSITION

The Path Marker profile consists of 6060T5 aluminium extrusion, anodized (silver colour) to 12 microns thickness.

Ecoglo G3-001 is adhesively fixed into the extrusion. The high visibility G3-001 is manufactured from extruded 6060T5 aluminium section. Custom made photoluminescent pigment is embedded in thermoset polyester carriers to integrally bond the active ingredients into the aluminium following curing at high temperature. The photoluminescent area is also recessed into protective channels.

INSTALLATION

The T5-101 Path Marker can be used on a range of substrates including carpet, concrete, timber, tiles, vinyl, steel and checker plate. Uni clamp assemblies can be used for installation onto steel mesh steps.

Installation is a simple process using polyurethane adhesive or using both fixers (screws supplied) and polyurethane adhesive. It can also be fitted over an industrial or commercial style carpet with no underlay. For thicker carpet, cut the carpet away and use a packer.

Consult Installation Instructions on website for full details and surface preparation.

Fixers (screws) can be used if adhesion is difficult.

(See order codes below for the product that best suits).

T5-101-1000 For polyurethane adhesive fixing

T5-101P-1000 Punched for screw fixing

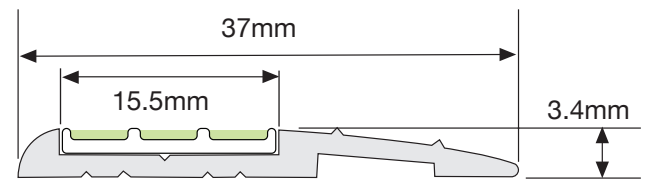
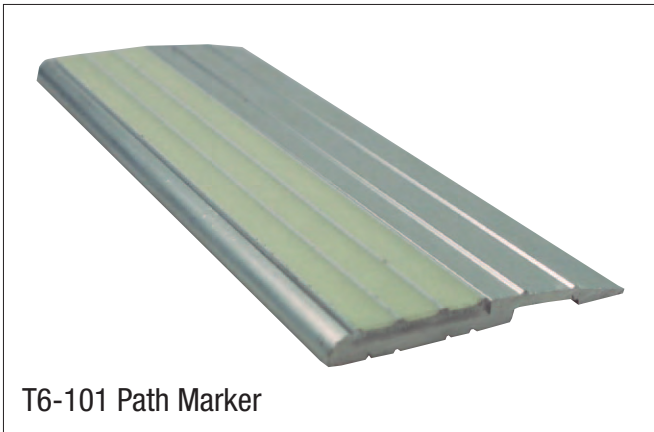

The T6-101 Path Marker is designed to ensure visibility of ramps, corridors and pathways in escape routes to meet NZBC Clause F6 'Visibility in Escape Routes'. The Path Marker will be effective in all light conditions including during failure of the main lighting.

PERFORMANCE

Independently tested in accordance with UL1994 for 10 metre visibility to meet NZBC Clause F6.

Risk Group C Building

30 minutes visibility
Minimum charging illuminance of 20 lux continuously during occupancy.

Risk Group B Building

90 minutes visibility
Minimum charging illuminance of 60 lux continuously during occupancy.

Outdoor or daylight installations will absorb enough natural light to be visible throughout the longest winter night.

The Path Marker is suitable for use indoors and outdoors.

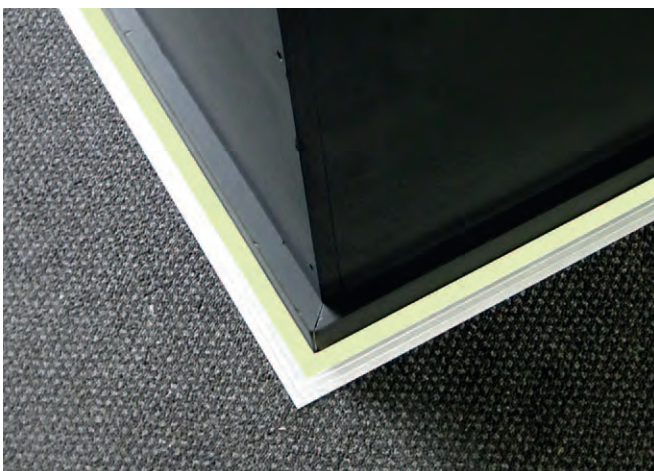

- UV Resistance - Loss of luminance after 1000 hrs ASTM G-155 Cycle 1 exposure: <10%: Pass
- Salt Spray Resistance - ASTM B117: Pass
- Washability - ASTM D4828: Pass
- Rate of Burning - ASTM D635: Pass
- Surface Flammability - ASTM E162: Pass
- Toxicity - Bombardier Toxic Gas Generation Test SMP800-C: Pass
- Radioactivity - ASTM D3648: Pass

SUPPLY

The product is available in 1 metre lengths.

COMPOSITION

The Path Marker profile consists of 6060T5 aluminium extrusion, anodized (silver colour) to 12 microns thickness.

Ecoglo G3-001 is adhesively fixed into the extrusion. The high visibility G3-001 is manufactured from extruded 6060T5 aluminium section. Custom made photoluminescent pigment is embedded in thermoset polyester carriers to integrally bond the active ingredients into the aluminium following curing at high temperature. The photoluminescent area is also recessed into protective channels.

INSTALLATION

Designed to fit adjacent to a wall or edging, the T6-101 Path Marker can be used on a range of substrates including carpet, concrete, timber, tiles, vinyl, steel and checker plate. Uni clamp assemblies can be used for installation onto steel mesh steps.

The T6-101 Path Marker can also be used to transition from one floor covering height to another.

Installation is a simple process using polyurethane adhesive or using both fixers (screws supplied) and polyurethane adhesive. It can also be fitted over an industrial or commercial style carpet with no underlay. For thicker carpet, cut the carpet away and use a packer.

Consult Installation Instructions on website for full details and surface preparation.

Fixers (screws) can be used if adhesion is difficult.
(See order codes below for the product that best suits).

T6-101-1000 For polyurethane adhesive fixing
T6-101P-1000 Punched for screw fixing

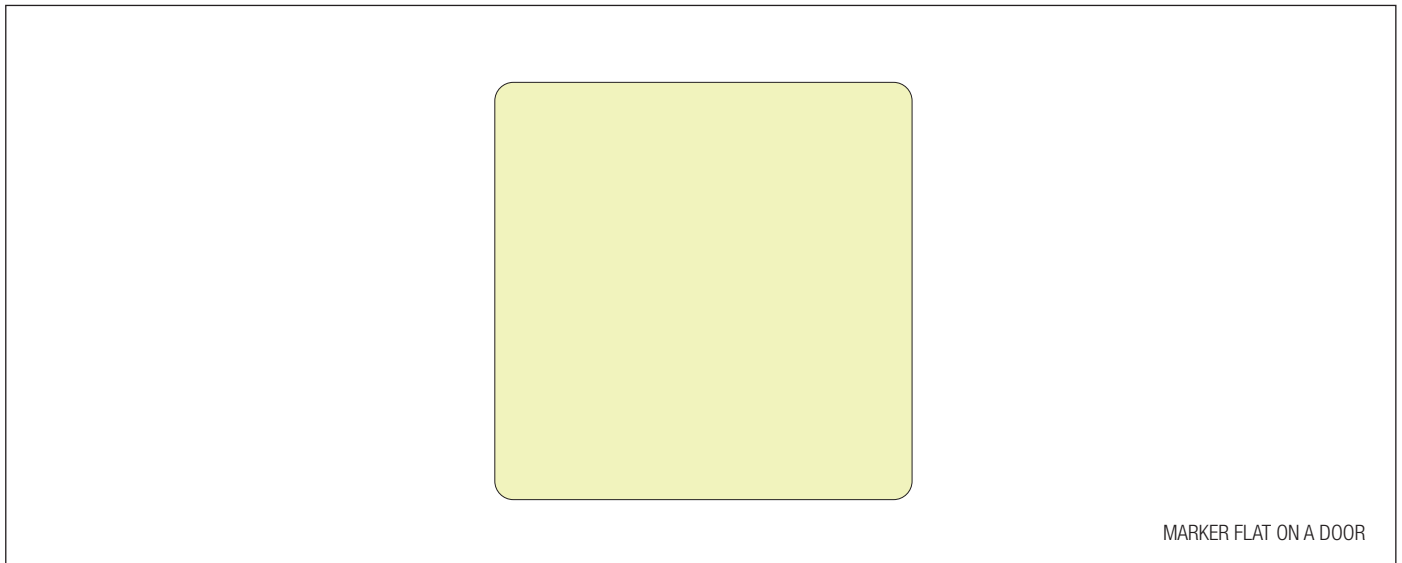

The Ecoglo “Door Handle Marker” is designed to ensure visibility of door handles in escape routes to meet NZBC Clause F6 “Visibility in Escape Routes”. The door handle marker will be effective during failure of the main lighting.

COMPLIANCE

The Ecoglo Door Handle Marker can be used in F6 Alternative Solutions as detailed below.

Phone Ecoglo or email Engineer@ecoglo.com for design advice for alternative solutions.

PERFORMANCE

Risk Group C Building

30 minutes visibility

Minimum charging illuminance of 20 lux continuously during occupancy.

Risk Group B Building

90 minutes visibility

Minimum charging illuminance of 60 lux continuously during occupancy.

UV Resistance - Loss of luminance after 1000 hrs ASTM G-155

Cycle 1 exposure: <10%: Pass

Salt Spray Resistance - ASTM B117: Pass

Washability - ASTM D4828: Pass

Rate of Burning - ASTM D635: Pass

Surface Flammability - ASTM E162: Pass

Toxicity - Bombardier Toxic Gas Generation Test SMP800-C: Pass

Radioactivity - ASTM D3648: Pass

SUPPLY

The product is available in 1 size - maximum viewing distance 24 metres.

PRODUCT CODE	PRODUCT NAME	MARKER DEFINITION	MARKER SIZE
S20-SQ-60	Door Handle Marker	Not applicable	60mm x 60mm

COMPOSITION

The high visibility flat panel is manufactured from 5005 0.9mm aluminium sheet. Custom made photoluminescent pigments are embedded in thermoset polyester carriers to integrally bond the active ingredients onto the aluminium sheet following curing at high temperature.

INSTALLATION

The marker is supplied with pre-fitted release tape for mounting flat on a door.

1. Identification**Product Name**

Ecoglo Step Nosings and Path Markers including:

F2-003-600, F2-003-700, F2-003-800, F2-003-900, F2-003-1000, F2-003-1100, F2-003-1200, F2-003-1300, F2-003-1400, F2-003-1500, F4-171-600, F4-171-700, F4-171-800, F4-171-900, F4-171-1000, F4-171-1100, F4-171-1200, F4-171-1300, F4-171-1400, F4-171-1500, F14-175-600, F14-175-700, F14-175-800, F14-175-900, F14-175-1000, F14-175-1100, F14-175-1200, F14-175-1300, F14-175-1400, F14-175-1500, G7-100, T5-101, T6-101

Manufacturer Details

Company: Ecoglo International Ltd

Address: 77 Kingsley St, Christchurch 8440, New Zealand

Phone No: +64 3 348 3781

2. Hazard Identification

Not classified as hazardous or dangerous as per GHS.

3. Composition/information on ingredients

Component	CAS No.	Proportion
Aluminium Alloy (6063)	-	80-95%
Strontium Aluminate based photoluminescent pigment	-	2-5%
Cross-linked thermoset polyester based resins	-	4-10%
Silicon Carbide	-	2-5%
Other components	-	< 3.4%

4. First-aid measures No special measures required.

5. Fire-fighting measures No special measures required.

6. Accidental release measures Not applicable.

7. Handling and storage Cut edges may be sharp. No special storage requirements.

8. Exposure controls and personal protection Wear gloves when handling.

9. Physical and chemical properties

Appearance:	Solid Strip material
Odour:	N/A
Melting point:	N/A
Specific gravity:	2.2-2.7 g/cc
Volatile:	N/A
Vapour pressure:	N/A
Vapour density:	N/A
Solubility in water:	Insoluble
Flammability:	Not easily combustible. Passes Bombardier SMP 800-C Toxic gas generation test
Explosivity:	Not explosive

10. Stability and reactivity

Hazardous reactions: None known

Radioactivity: Not Radioactive

11. Toxicological information No toxicological properties.

12. Ecological information No ecological hazards.

13. Disposal considerations Offcuts can be sent for aluminium recycling.

14. Transport information Not restricted.

15. Regulatory information None applicable to product.

16. Any other relevant information None.

This information is offered in good faith to the best of our current knowledge. No warranty, expressed or implied, regarding the accuracy of this data, the hazards connected with use of the material, or the results to be obtained from the use thereof, is made. Ecoglo International Ltd. assumes no responsibility for damage or injury from the use of this product.

1. Identification

Product Name

Ecoglo Step Edge Contrast including:

E14-075-600, E14-075-700, E14-075-800, E14-075-900, E14-075-1000, E14-075-1100, E14-075-1200, E14-075-1300, E14-075-1400, E14-075-1500, E14-075-2450, E14-075-3060, E2-071-600, E2-071-700, E2-071-800, E2-071-900, E2-071-1000, E2-071-1100, E2-071-1200, E2-071-1300, E2-071-1400, E2-071-1500, E2-071-2450, E2-071-3060, E4-073-600, E4-073-700, E4-073-800, E4-073-900, E4-073-1000, E4-073-1100, E4-073-1200, E4-073-1300, E4-073-1400, E4-073-1500, E4-073-2450, E4-073-3060

Manufacturer Details

Company: Ecoglo International Ltd
 Address: 77 Kingsley St, Christchurch 8440, New Zealand
 Phone No: +64 3 348 3781

2. Hazard Identification

Not classified as hazardous or dangerous as per GHS.

3. Composition/information on ingredients

Component	CAS No.	Proportion
Aluminium Alloy (6063)	-	50-80%
Strontium Aluminate based photoluminescent pigment	-	0-10%
Cross-linked thermoset polyester based resins	-	10-30%
Silicon Carbide	-	5-20%
Other components	-	< 0.5%

4. First-aid measures No special measures required.

5. Fire-fighting measures No special measures required.

6. Accidental release measures Not applicable.

7. Handling and storage Cut edges may be sharp. No special storage requirements.

8. Exposure controls and personal protection Wear gloves when handling.

9. Physical and chemical properties

Appearance:	Solid Strip material
Odour:	N/A
Melting point:	N/A
Specific gravity:	2.2-2.7 g/cc
Volatile:	N/A
Vapour pressure:	N/A
Vapour density:	N/A
Solubility in water:	Insoluble
Flammability:	Not easily combustible. Passes Bombardier SMP 800-C Toxic gas generation test
Explosivity:	Not explosive

10. Stability and reactivity

Hazardous reactions:	None known
Radioactivity:	Not Radioactive

11. Toxicological information No toxicological properties.

12. Ecological information No ecological hazards.

13. Disposal considerations Offcuts can be sent for aluminium recycling.

14. Transport information Not restricted.

15. Regulatory information None applicable to product.

16. Any other relevant information None.

This information is offered in good faith to the best of our current knowledge. No warranty, expressed or implied, regarding the accuracy of this data, the hazards connected with use of the material, or the results to be obtained from the use thereof, is made. Ecoglo International Ltd. assumes no responsibility for damage or injury from the use of this product.

1. Identification

Product Name

Ecoglo Guidance Strips and Handrail Markers including: MS-26-1000, G3-001-1000, G3-001-1500, G3-001-3060, G4-001-1000, G6-003-1000, G6-003-3060, H3-001-1000, H3-001-1500, H3-001-3060, H5-001-1000, H5-001-3060

Manufacturer Details

Company: Ecoglo International Ltd

Address: 77 Kingsley St, Christchurch 8440, New Zealand

Phone No: +64 3 348 3781

2. Hazard Identification

Not classified as hazardous or dangerous as per GHS.

3. Composition/information on ingredients

Component	CAS No.	Proportion
Aluminium Alloy (6063)	-	60-80%
Strontium Aluminate based photoluminescent pigment	-	5-15%
Cross-linked thermoset polyester based resins	-	10-30%
Other components	-	<0.2%

4. First-aid measures No special measures required.

5. Fire-fighting measures No special measures required.

6. Accidental release measures Not applicable

7. Handling and storage Cut edges may be sharp. No special storage requirements.

8. Exposure controls and personal protection Wear gloves when handling.

9. Physical and chemical properties

Appearance: Solid Strip material

Odour: N/A

Melting point: N/A

Specific gravity: 2.2-2.7 g/cc

Volatile: N/A

Vapour pressure: N/A

Vapour density: N/A

Solubility in water: Insoluble

Flammability: Not easily combustible. Passes Bombardier SMP 800-C Toxic gas generation test

Explosivity: Not explosive

10. Stability and reactivity

Hazardous reactions: None known

Radioactivity: Not Radioactive

11. Toxicological information No toxicological properties.

12. Ecological information No ecological hazards.

13. Disposal considerations Offcuts can be sent for aluminium recycling

14. Transport information Not restricted.

15. Regulatory information None applicable to product.

16. Any other relevant information None.

This information is offered in good faith to the best of our current knowledge. No warranty, expressed or implied, regarding the accuracy of this data, the hazards connected with use of the material, or the results to be obtained from the use thereof, is made. Ecoglo International Ltd. assumes no responsibility for damage or injury from the use of this product.

Designing your photoluminescent path marking system

Introduction

This document is aimed at those wishing to design photoluminescent path marking systems to meet New Zealand Building Code Clause F6 “Visibility in Escape Routes”.

This document explains:

- Where Ecoglo path marking systems are appropriate to use;
- Which Ecoglo markings should be used and where they should be installed;

- What ongoing inspections should be carried out.

For more detail explaining how Ecoglo markings meet the requirements of Clause F6, please refer to the Technical Justification for Ecoglo Markings document.

Go to www.ecoglo.co.nz

From *Homepage*, select *Technical*, then *F6 compliance*.

Where can Ecoglo path markings be used?

Ecoglo produces high performance, high durability photoluminescent products for step edges, handrails, paths, doors, and hazard marking.

There are two basic requirements for Ecoglo markings to be appropriate:

1. There needs to be a clearly definable escape path that can be marked;
2. There needs to be sufficient charging light (natural or electrical) on the markings to ensure they will remain “reasonably visible” for the times specified in Clause F6.3.4.

If these requirements cannot be met, an electrical emergency lighting system will be needed.

In some buildings the most appropriate complete solution may be a combination of Ecoglo markings and electrical emergency lighting.

1. Clearly Definable Escape Path

The illustrations below show examples of clearly definable escape paths that are suitable for highlighting with Ecoglo markings. In many buildings the complete escape route that is required to be made visible in an emergency (ie to meet Clause F6) is a clearly definable path.

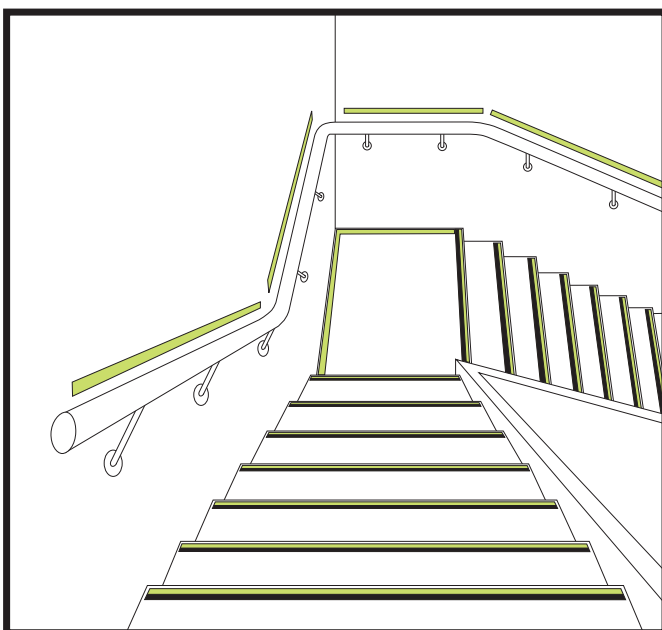

Steps and Stairways

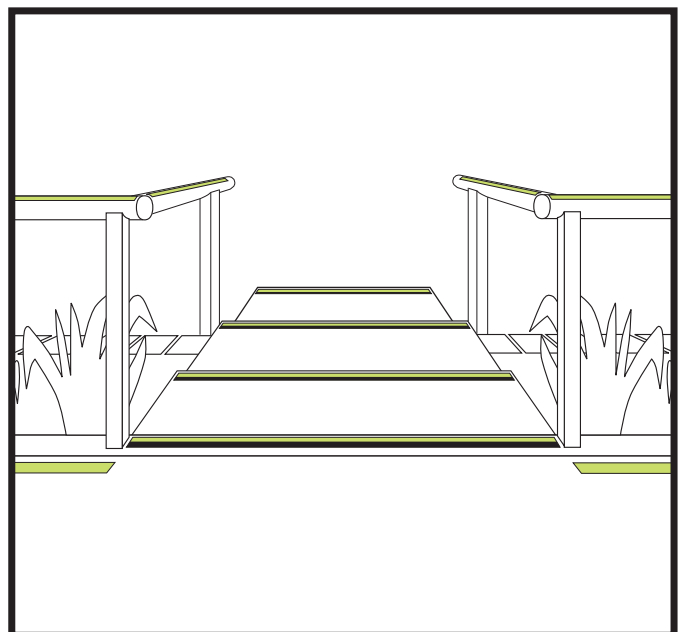

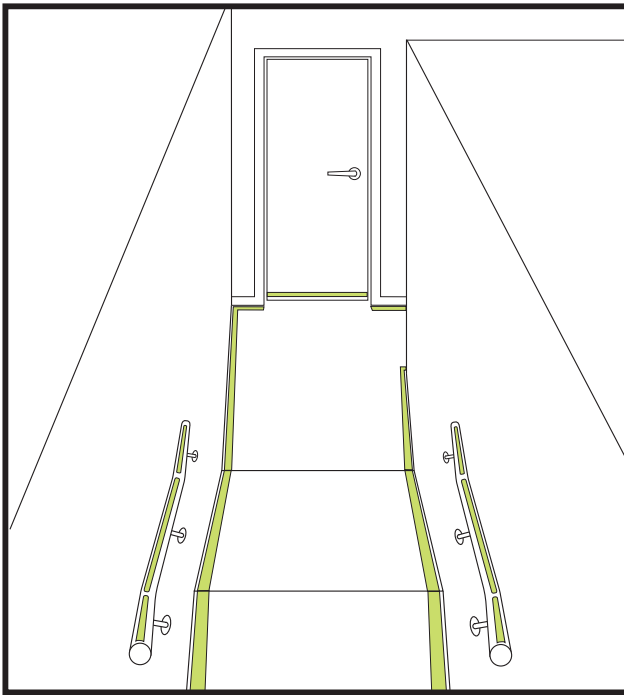

Corridors and Ramps

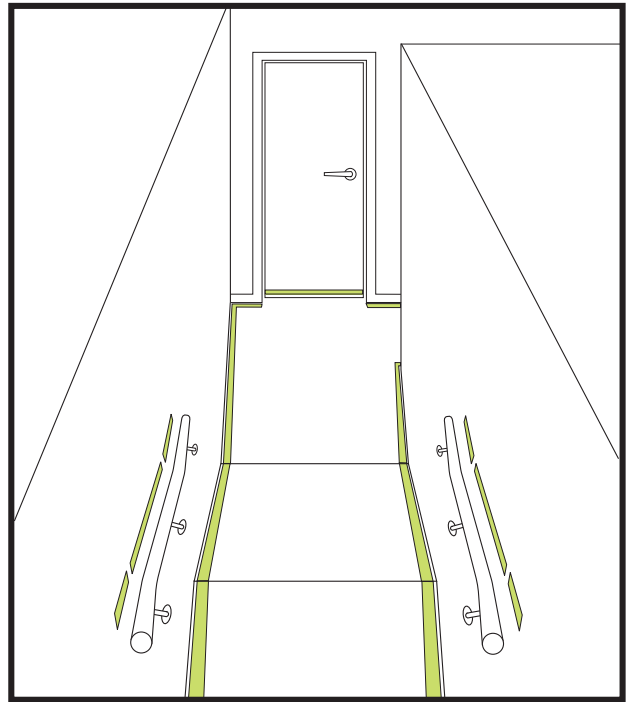

Corridors and Ramps

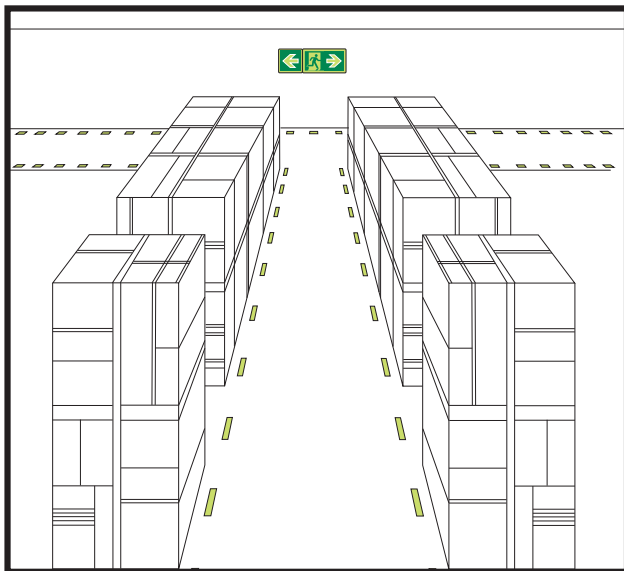

Open Spaces

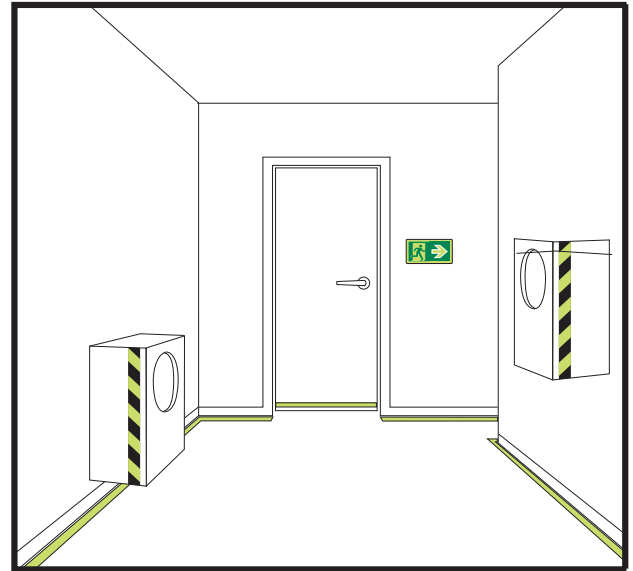

Obstacles

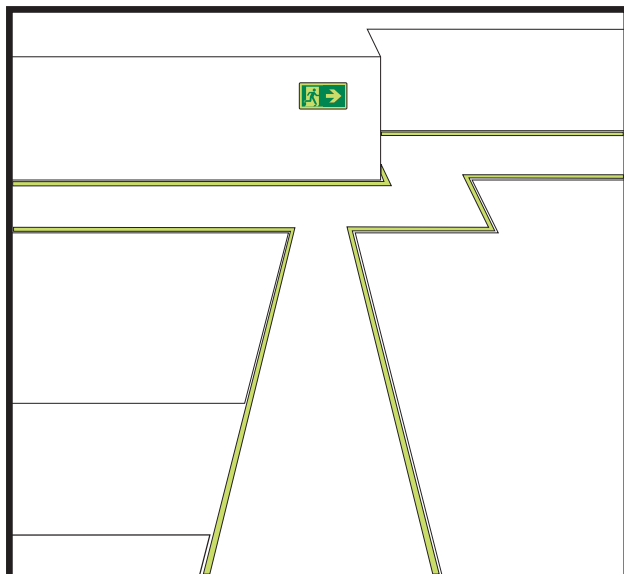

Open Spaces

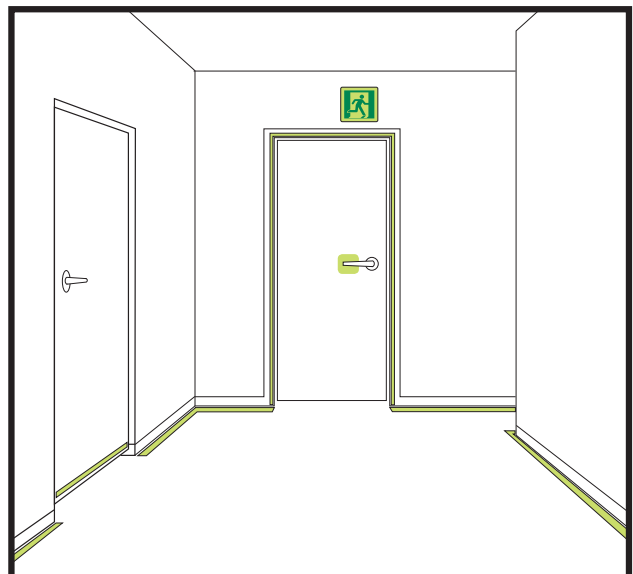

Doorways and entries to a safe place

Limitations

Obstructions

NZBC Clause C requires escape routes to be unobstructed. However it may still be foreseeable that obstructions may be inadvertently left in an escape route. Where the escape route consists of stairs, the likelihood is that an obstruction large enough to cause a trip hazard would be highlighted by the step edge markings. However, on a level escape route where the markings are only on the sides of the path, there is potential for an obstruction to remain unseen. It is important for the system designer to be aware of this risk, and consider factors such as public access, familiarity of the users with the escape route, and likelihood of obstructions.

Dangerous Machinery

If it can be foreseen that, in the event of failure to the normal lighting, machinery or equipment could present an unseen danger to people in the area, and that hazard marking would not alleviate that danger, then emergency electrical lighting should be used to illuminate the danger.

Open Spaces

Where an escape route is required through an open space, the perimeter of the escape path can be marked, as previously shown.

If the open space acts like a concourse, with multiple routes rather than one or more clear paths through it, path marking is not appropriate and lighting is a better option.

2. Sufficient Charging Light

Building Risk Groups

NZBC F6.3.4 specifies the duration that the specified features must remain reasonably visible.

To ensure that Ecoglo markings meet the required visibility duration, they must be charged with natural or electric lighting at a sufficient brightness and for sufficient time.

NZBC Clause F6 Risk Group C¹ buildings require a 30 minute visibility duration.

NZBC Clause F6 Risk Group B² buildings require a 90 minute visibility duration.

NZBC Clause F6 Risk Group A³ buildings require an indefinite visibility duration.

1. Risk Group C Buildings are those with no more than 1000 occupants and an evacuation time of no more than 30 minutes, where the occupants are not required to remain in the building during an emergency.

2. Risk Group B Buildings are those with more than 1000 occupants and an evacuation time of up to 90 minutes, where the occupants are not required to remain in the building during an emergency.

3. Risk Group A Buildings are those whose occupants are required to remain in the building until the main lighting is restored, or whose evacuation time is greater than 90 minutes.

An indefinite visibility duration cannot be met (indoors) with Ecoglo markings, however Ecoglo may provide useful fail-safe instant strike while the main back-up system is firing up and if the emergency power generator activates normal lighting in the area, Ecoglo markings may be sufficient to meet F6 without any emergency luminaires.

Outdoor use

(That part of an escape route between the building shell and a safe place)

There is no need for charging with any electric lighting: Ecoglo markings will meet the charging requirements to ensure compliance with Clause F6 for all building risk groups.

Indoor use

How to ensure charging is at sufficient brightness and for sufficient time to meet the durations specified in F6.3.4:

What lamps can be used?

In general, any lamp with a colour temperature of 4000K or more is a suitable charging light.

4000K colour temperature is the norm for offices, commercial, and most industrial lighting.

The main source of lower colour temperature lamps is halogen downlights, or “mood” lighting where lamps may be specified at around 3000K “warm white”. These lamps will need to have greater brightness to charge Ecoglo markings as much as 4000K lamps.

How long do Ecoglo markings need to be charged for?

Ecoglo markings are designed to meet Clause F6 following no more than 5 minutes charging.

It is usually acceptable to design a system where a building (or building space) has no lights turned on prior to occupation. This is appropriate where it is reasonable to assume that if a building space is dark, the first occupier will turn on the lights.

Assuming the worst case where the building is first entered while it is still dark, or the markings are in a room with no windows, for every second that the lights have been turned on, the markings will accumulate several seconds of operational charge.

Therefore the time the markings will remain reasonably visible is greater than the time since first occupation. This allows for safe evacuation.

Designers should be aware of scenarios where this rationale may not be appropriate, such as a tall building with elevators which can rapidly take someone to an upper floor, from where their escape time could be much more than the time since first occupancy.

Also, in crowd occupancies, it is recommended that the public not be allowed entry to the building until the markings have full operational charge.

What illuminance is needed to charge Ecoglo markings?

NZBC Clause F6 Risk Group C

(30 minutes of visibility required):

Ecoglo markings require a minimum of 20 lux (for a period of 5 minutes).

NZBC Clause F6 Risk Group B

(90 minutes of visibility required):

Ecoglo markings require a minimum of 60 lux (for a period of 5 minutes).

Note that an illuminance of 20 lux is the minimum amount of light allowed by Clause G8.3 (Artificial Light) in an occupied space of a building.

In most practical situations there is a lot more than 20 lux or even 60 lux and therefore the Ecoglo markings obtain full operational charge more quickly, and remain reasonably visible for a lot longer than F6 requires. See Appendix A for typical illuminances in NZ buildings.

Therefore for most buildings all occupied spaces will have sufficient light to charge the Ecoglo markings sufficiently.

Will the prescribed charging light be on whenever the markings may need to be charged?

The designer should check those parts of the escape route that are not normally occupied and lit when the markings need to be charged. For example an enclosed stairwell used only in emergencies and not normally lit.

For these spaces a management process must be implemented to make sure that markings in these spaces are at operational charge whenever needed.

Suitable management processes include:

- The escape route is daylight, and the only non-daylight use of the building is for up to 2.5 hours after sunset.
- The escape route lights will be switched on manually by people occupying the building: warning signs will be placed by the light switches.
- Timer circuitry is (automatically) initiated by the first person entering the building, and ensures the escape route is lit with 150 lux for 10 minutes every hour.
- Smart sensor circuitry is (automatically) initiated by the first person entering the building, and ensures the escape route is lit with a minimum of 20 lux (Risk Group C) or 60 lux (Risk Group B) for 10 minutes, then gradually ramps down to 5 lux if the space remains unoccupied. Motion sensors immediately bring the light back up to the desired “normal” lighting, and in the absence of occupation, the light ramps back down to 5 lux again.
- Circuits link lighting so that when lights are switched on in an occupied space all signs in all escape paths from the occupied space are lit.

Where it is considered that a management process such as those listed above is not appropriate, electrical emergency lighting should be installed.

Which Ecoglo path markings should be used and where should they be installed?

The following information specifies the recommended Ecoglo product in each situation where Clause F6 may require path marking.

Note that Clause F6 requires all changes in level en route to a safe place to be marked, but level travel in the first 20m of the escape path does not usually need to be marked.

There are alternative Ecoglo products that may also be appropriate to meet specific architectural requirements. Contact Ecoglo for details. (Telephone 03 348-3781).

To ensure that the Ecoglo markings will remain in place once installed, installers must follow the most recent installation instructions for each product.

Steps and Stairways

Ecoglo F4-171 or F14-175 nosings along the horizontal leading edge of all steps including the landing step at the top of any flight of stairs.

The nosings should normally be set back from the sides of the stairway by 50-100mm at each side. Ecoglo stocks F4-171 and F14-175 in 100mm increments from 600mm to 1500mm to suit all step widths from 650mm upwards. For step widths greater than 1600mm, multiple nosings should be installed with a 5mm drainage/thermal expansion between the nosings.

Ecoglo H3-001 handrail strip along the top of all handrails adjacent to the steps or Ecoglo MS26 on the wall beside the handrail. Up to 100mm gaps are allowed where there are bends or curves in the handrail.

Handrail Alternatives

Clause F6 requires safety features required by Clause D1 to be marked. Handrails are safety features that are required by Clause D1 and therefore must be marked. Where it is considered inappropriate or impractical to install H3-001 on a handrail, a wider and brighter strip (MS26) can be installed on the wall next to the handrail. The strip must be within 100mm horizontal and 50mm vertical of the handrail.

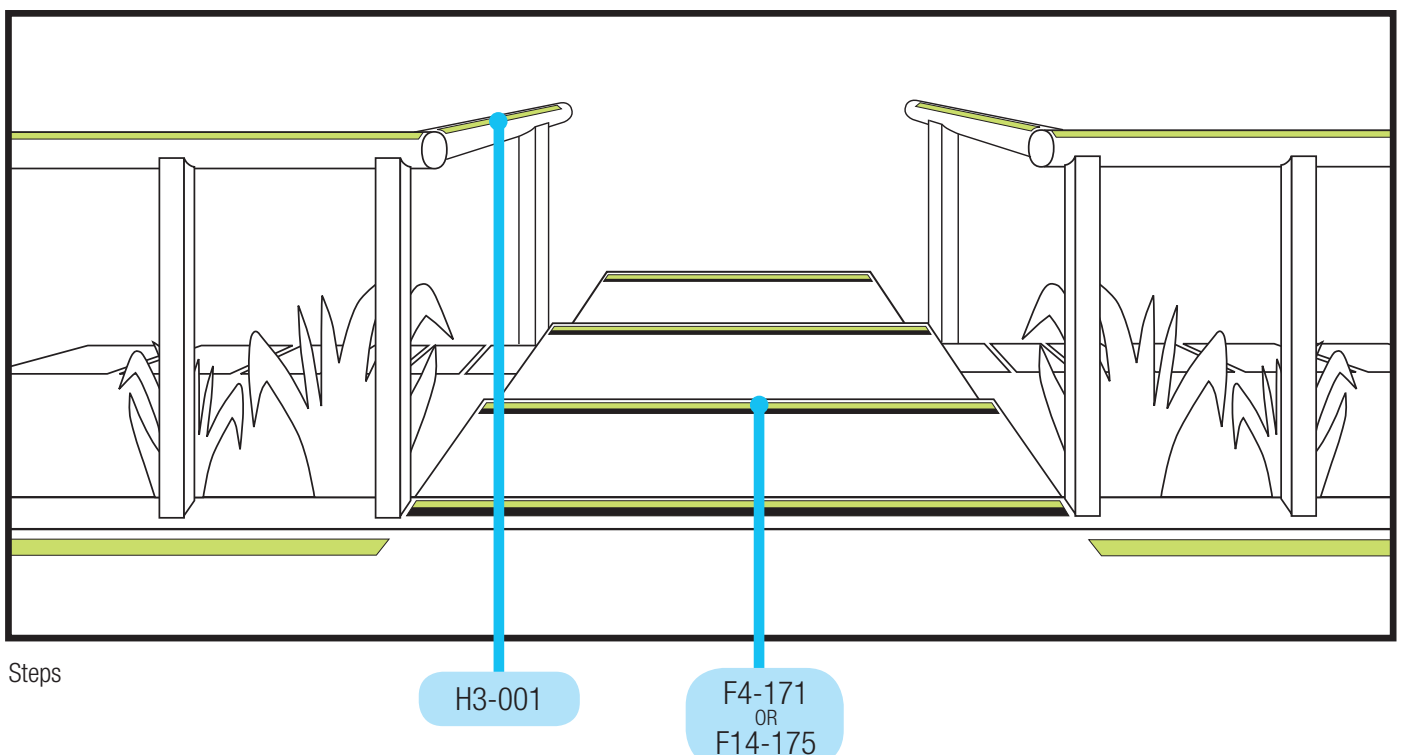

Stairway Landings

Ecoglo T6-101 (usually for exterior use) or G3-001 (16mm wide, interior use) or G4-001 (12mm wide, interior use) path marking strips along the complete perimeter of the landing.

The markings should be mounted either on the floor within 100mm of the wall, or on the wall or skirting board within 100mm of the floor.

Any doorways that should not be entered should have markings running past the door on the floor within 100mm of the door or on the door within 100mm of the floor.

Up to 100mm gaps are allowed where continuous marking would be impractical.

Ecoglo H3-001 handrail strip along the top of all handrails or MS26 on the wall beside the handrail. Up to 100mm gaps are allowed where there are bends or curves in the handrail.

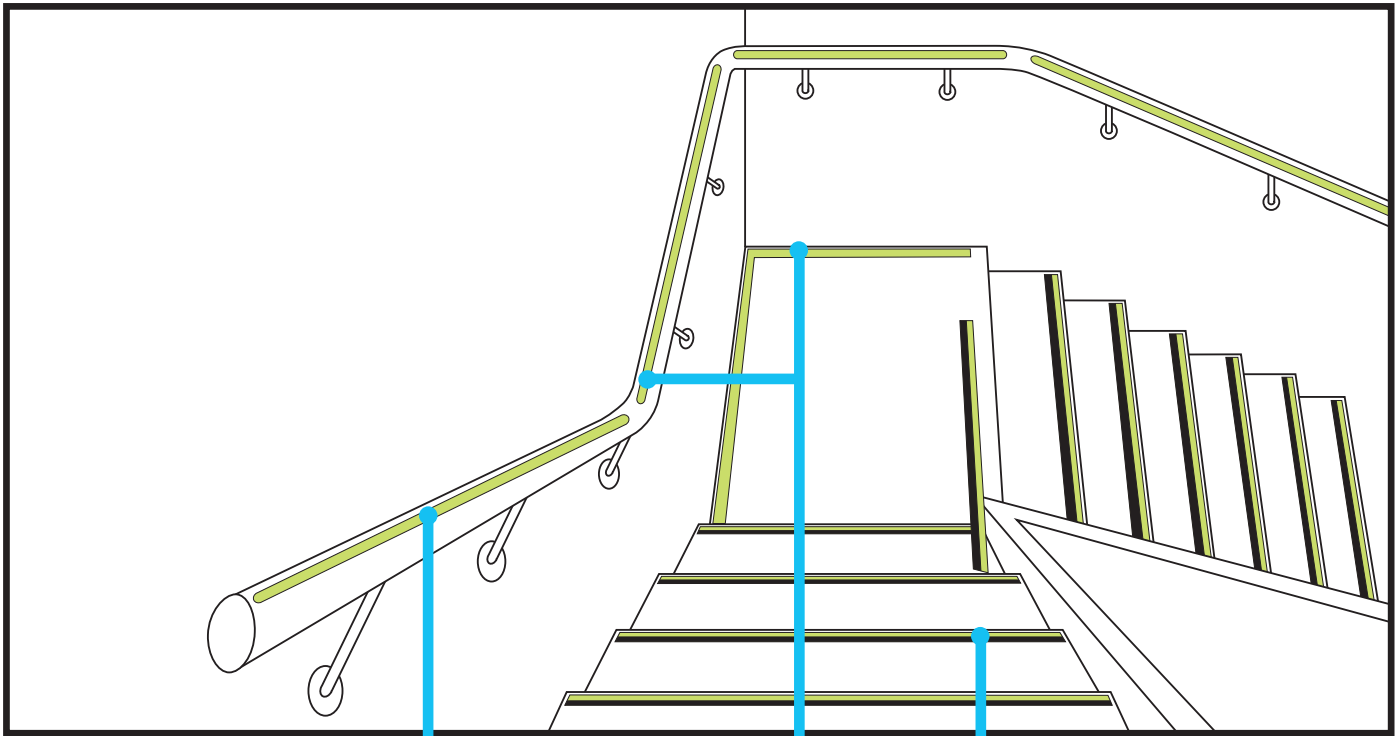

H3-001

T6-101
OR
G3-001

F4-171
OR
F14-175

MS26

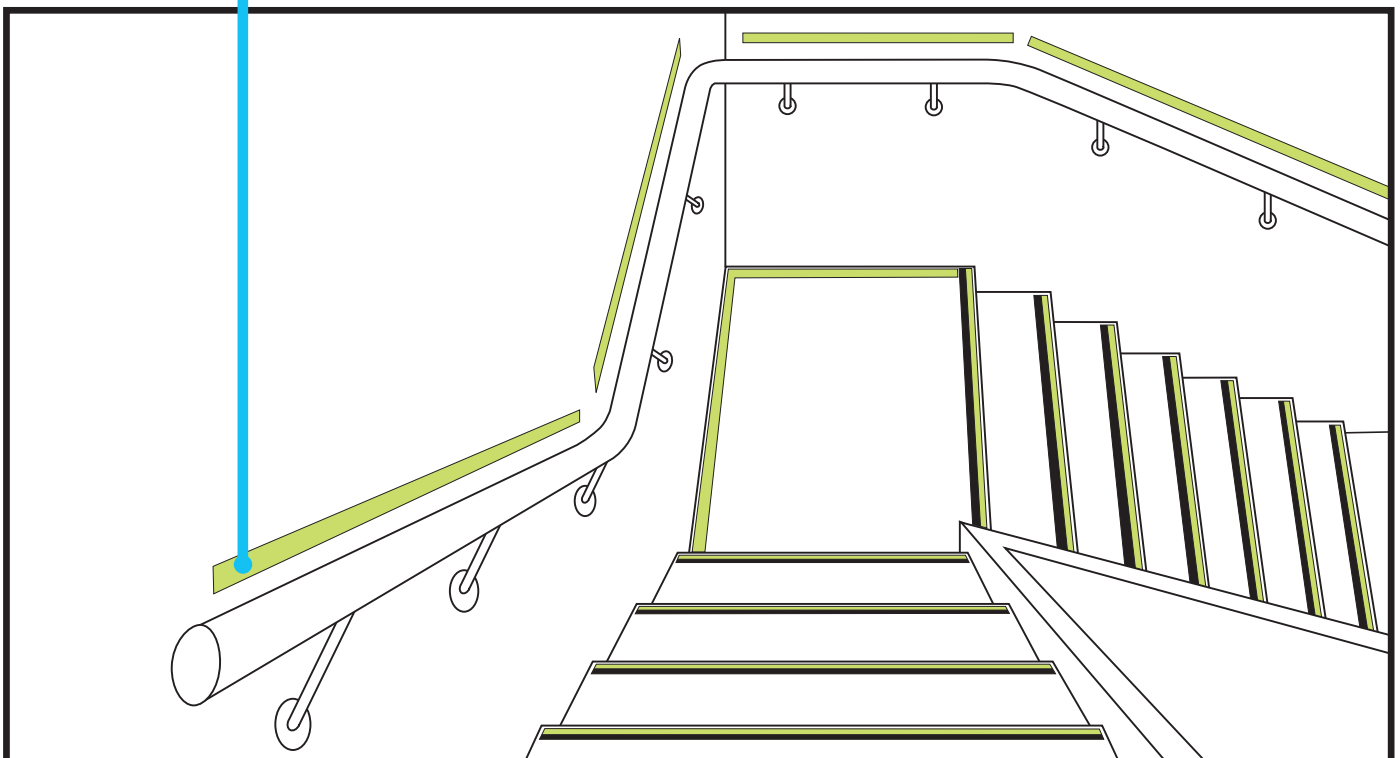

Ramps and Decks

Ecoglo T6-101 path marking strip along both sides of the ramp or deck.

The strip can be placed on top of an upstand edging as long as it is within 100mm of the walking surface.

Ecoglo H3-001 along the top of all handrails adjacent to the path needing to be marked or Ecoglo MS26 on the wall beside the handrail. Up to 100mm gaps are allowed where there are bends or curves in the handrail.

Note:

Most accessible ramps need to be marked. However, an accessible ramp within the first 20m of an escape route and with a gradient no steeper than 1:20 does not need to be marked. Clause D1 states that accessible ramps no steeper than 1:20 do not need a handrail. This indicates they present no greater risk of injury or impediment to movement (as written in F6.3) than a level surface.

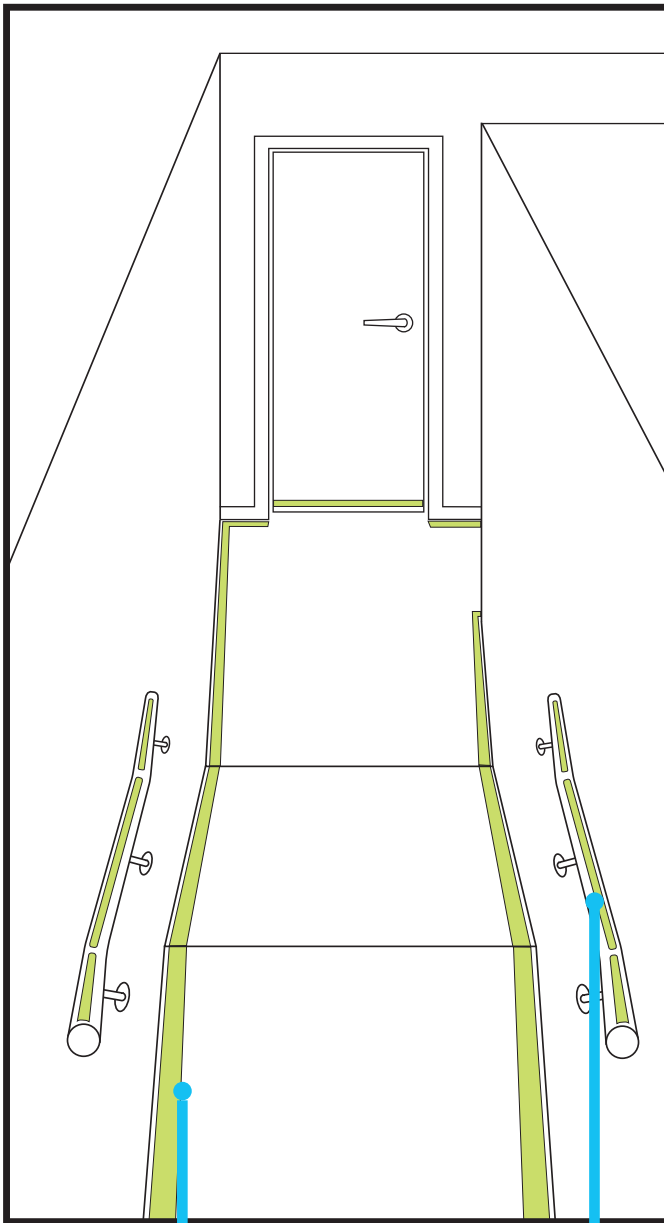

Ramps

T6-101

H3-001

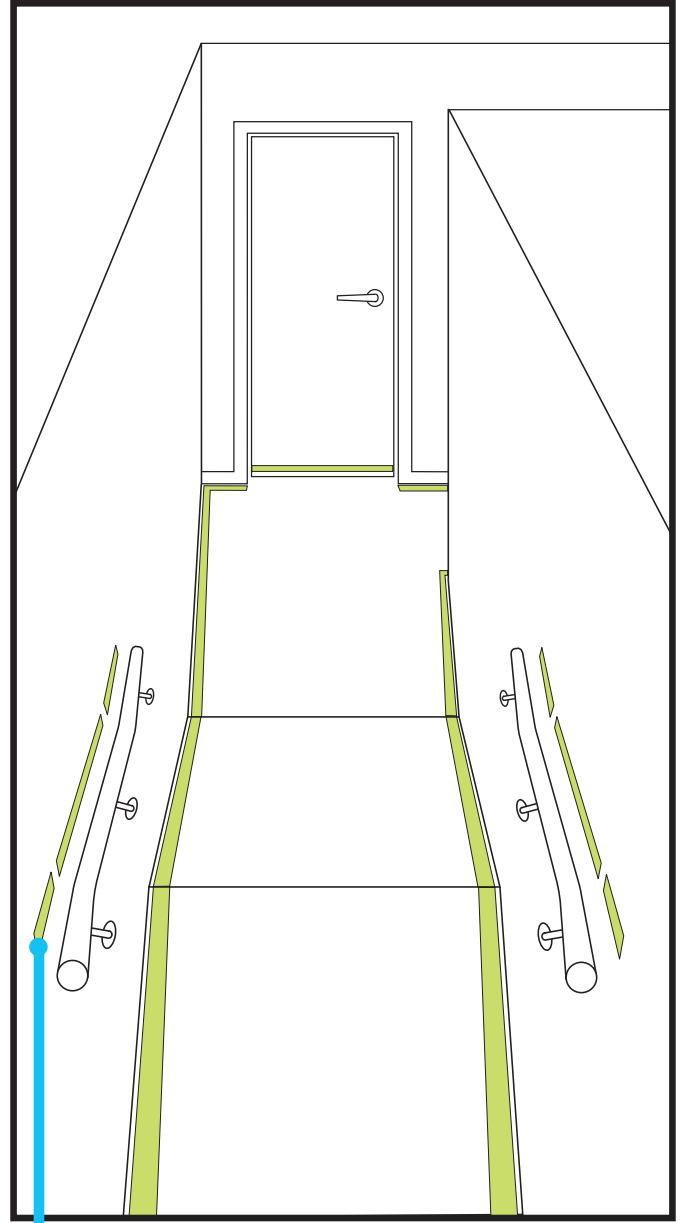

MS26

Corridors

Ecoglo T6-101 or G3-001 (16mm wide) or G4-001 (12mm wide) path marking strips along both sides of the corridor.

The markings should be mounted either on the floor within 100mm of the wall, or on the wall or skirting board with-

in 100mm of the floor. Any doorways that should not be entered should have markings running past the door on the floor within 100mm of the door or on the door within 100mm of the floor. Up to 100mm gaps are allowed where continuous marking would be impractical.

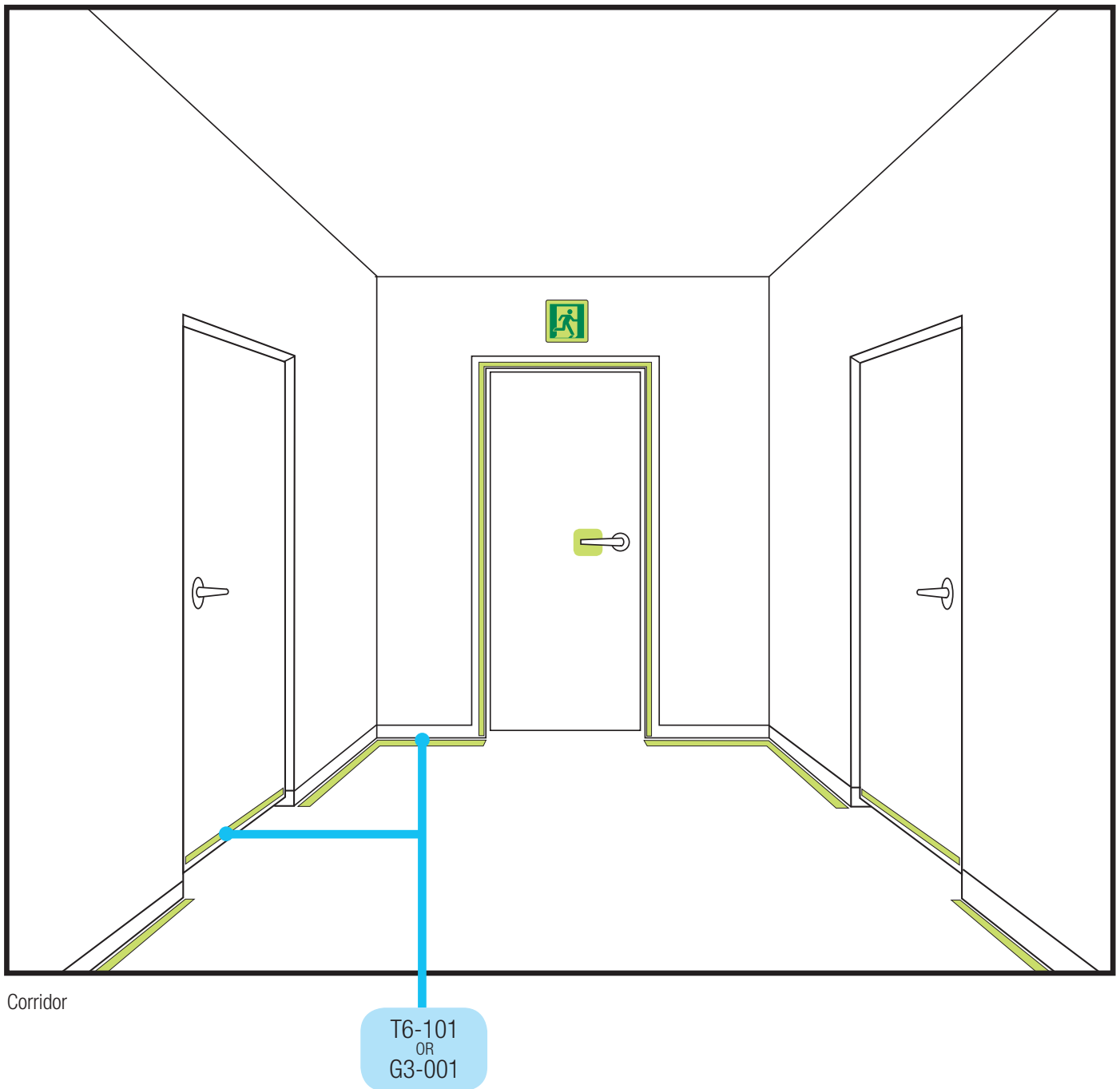

Paths through Open Spaces

Ecoglo T5-101 path marking strips along both sides of the designated path.

Up to 100mm gaps are allowed where continuous marking would be impractical.

Ecoglo G7-100 path markers can be applied as discontinuous markings in the following circumstances:

- Where it is not practical to install continuous markings (for example because of uneven ground or floor surfaces, or the presence of working forklifts); and
- Where all occupants are familiar with the escape route and the escape path markings; and
- Where the minimum frequency of markers is 1 per metre.
- Where the escape route has many changes in direction and few straight runs of 10 metres or more, the minimum frequency of markers should be 3 per metre.

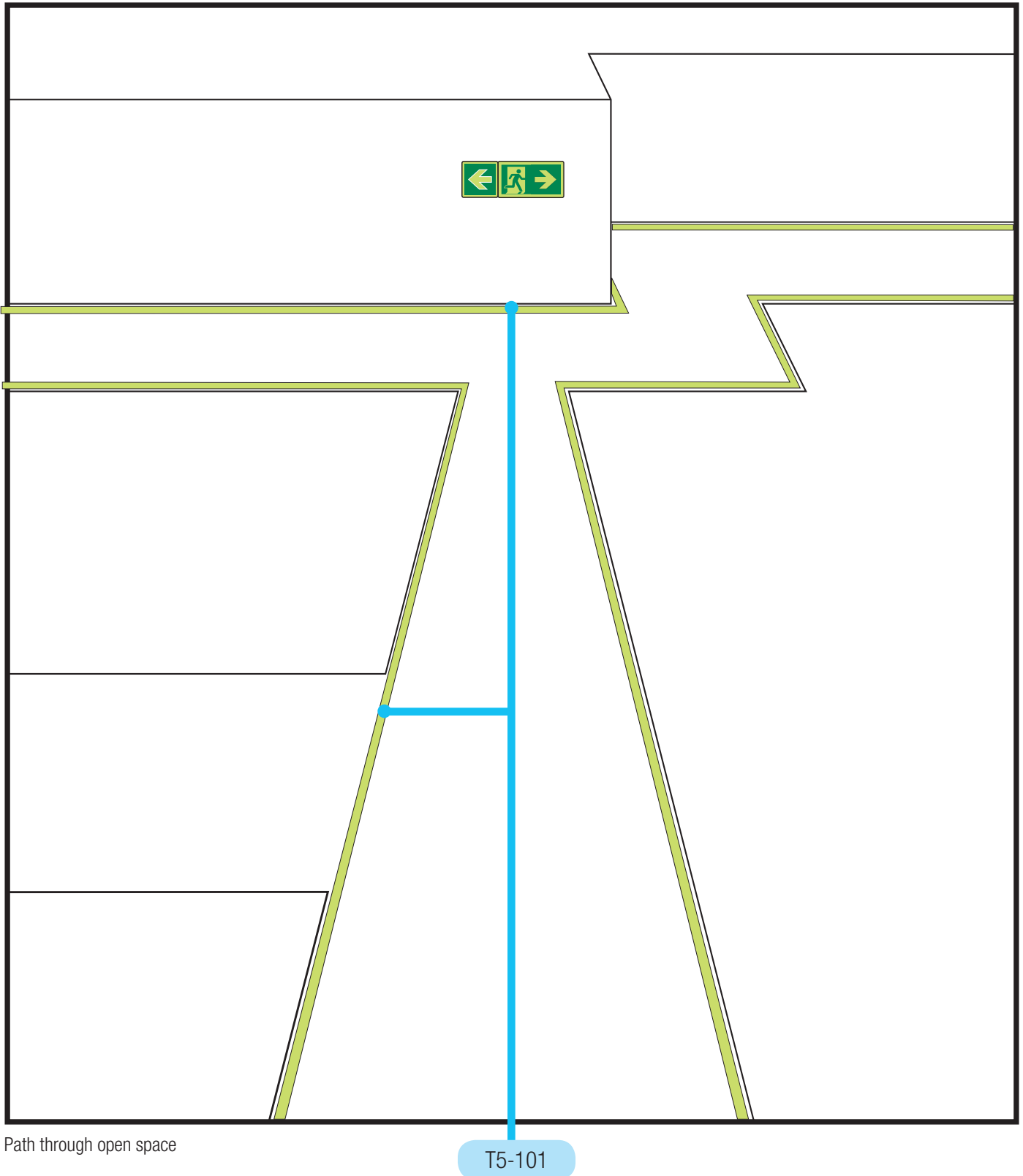

Path through open space

T5-101

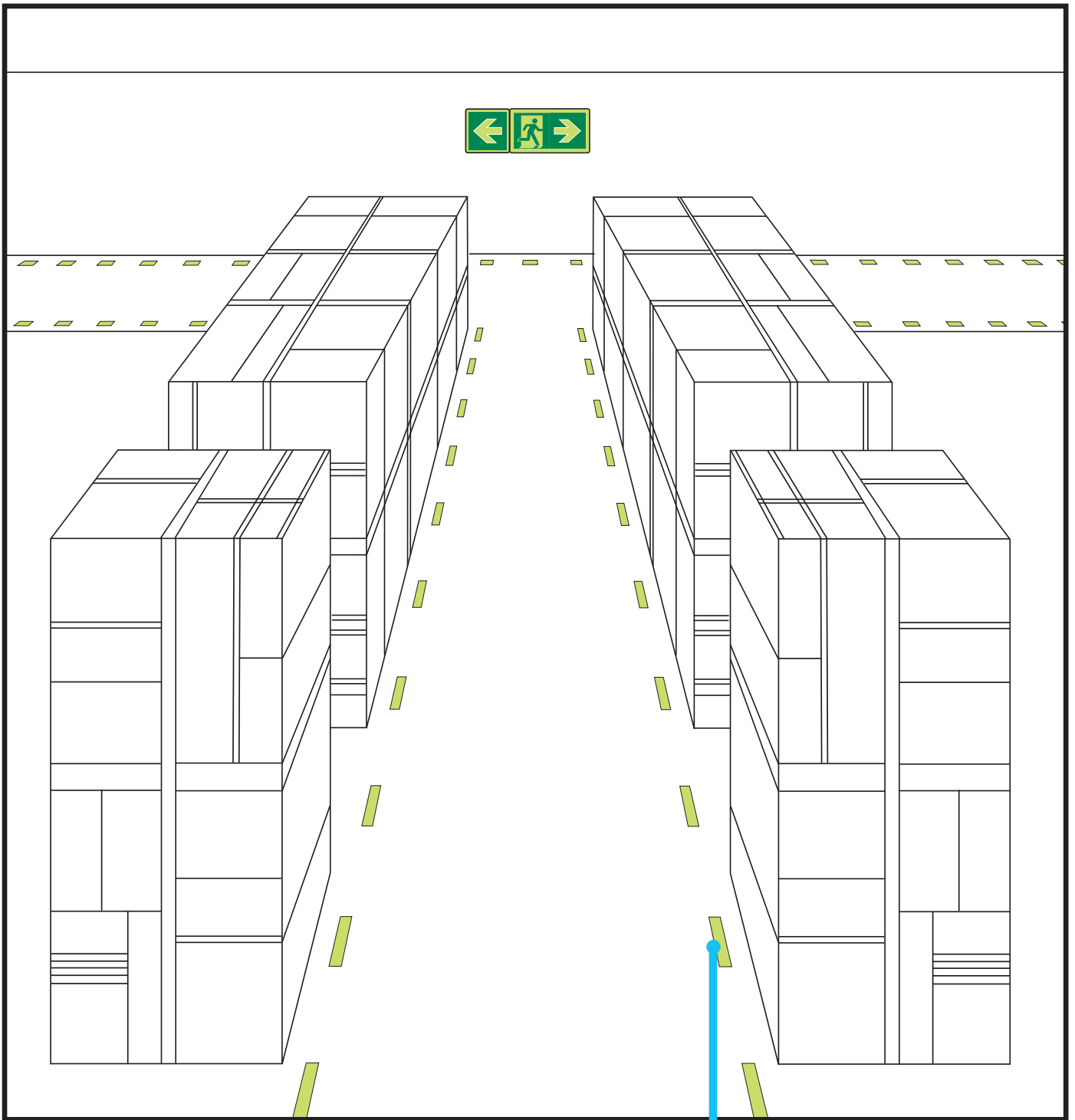

Path through open space (where occupants are familiar with the escape route)

G7-100

Obstacles

Ecoglo Hazard marking tape applied to any obstacles at or below 2 metres in height and projecting more than 100mm into an escape route.

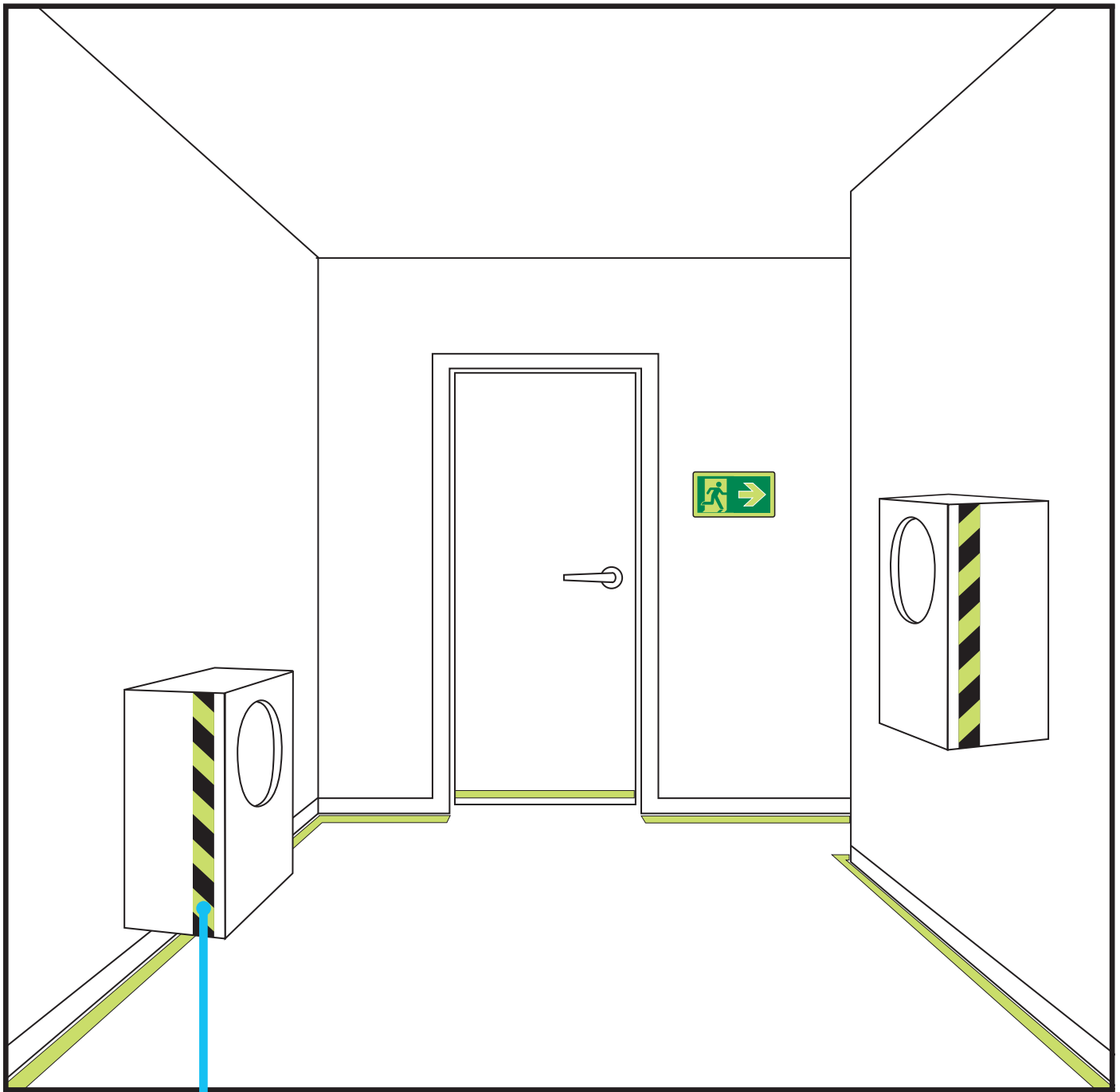

Obstacles

Hazard
Marking
Tape

Escape Doors and Entries to a Safe Place

Ecoglo G3-001 strips to mark the complete door surround.

Ecoglo SQ60 door handle marker on the door as close to the handle mechanism as possible to highlight its position.

In areas where there is a reasonably foreseeable risk of smoke obscuring the top of the doorway and/or the installed

exit sign at the door, a pictogram exit sign (S20-RM1616UN-16m) should be placed on the door, centred horizontally, and with the top of the sign no higher than 450mm above floor level.

Note that this is in addition to the requirements under Clause F8 for exit signs.

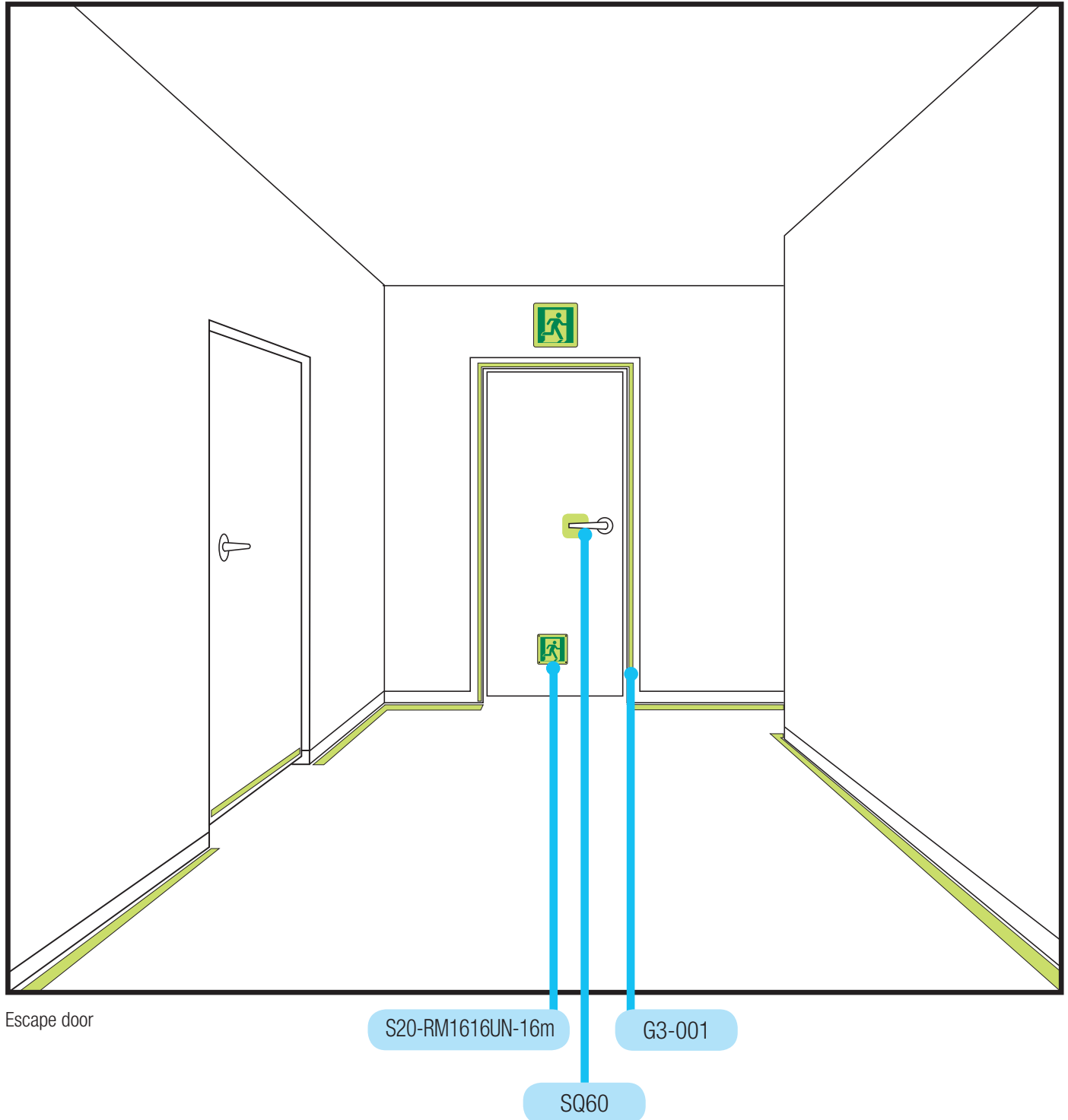

Unexpected Direction Changes & Merging Routes

Ecoglo S20-RML2916-16m and S20-RMR2916-16m (for up to 16 metre viewing distance), or S20-RML4223-24m and S20-RMR4223-24m (for up to 24m viewing distance) where there are direction changes which may seem

surprising or sudden to someone escaping, or intersections where one way is a dead end.

They should be mounted on a vertical surface, the top of the signs no more than 450mm above floor level. Note that this is in addition to the requirements under Clause F8 for exit signs.

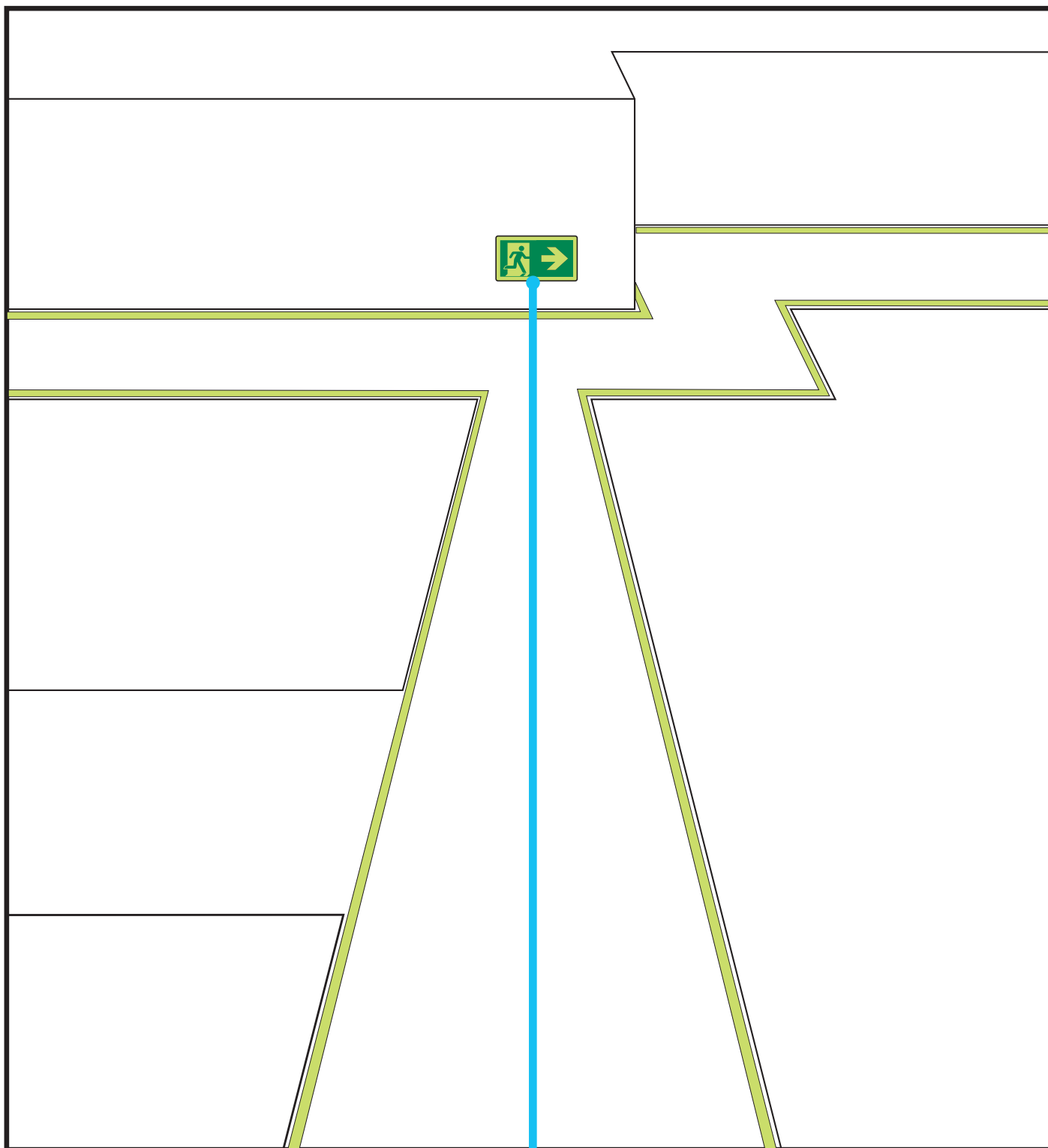

Merging routes

S20-RMR4223-24m

Wide Paths

T5-101, 300mm lengths with a frequency of 1 per 3m, to form “lane markings” where the escape route is required to be 3m wide or greater, and spaced to ensure that no individual lane is wider than 3m.

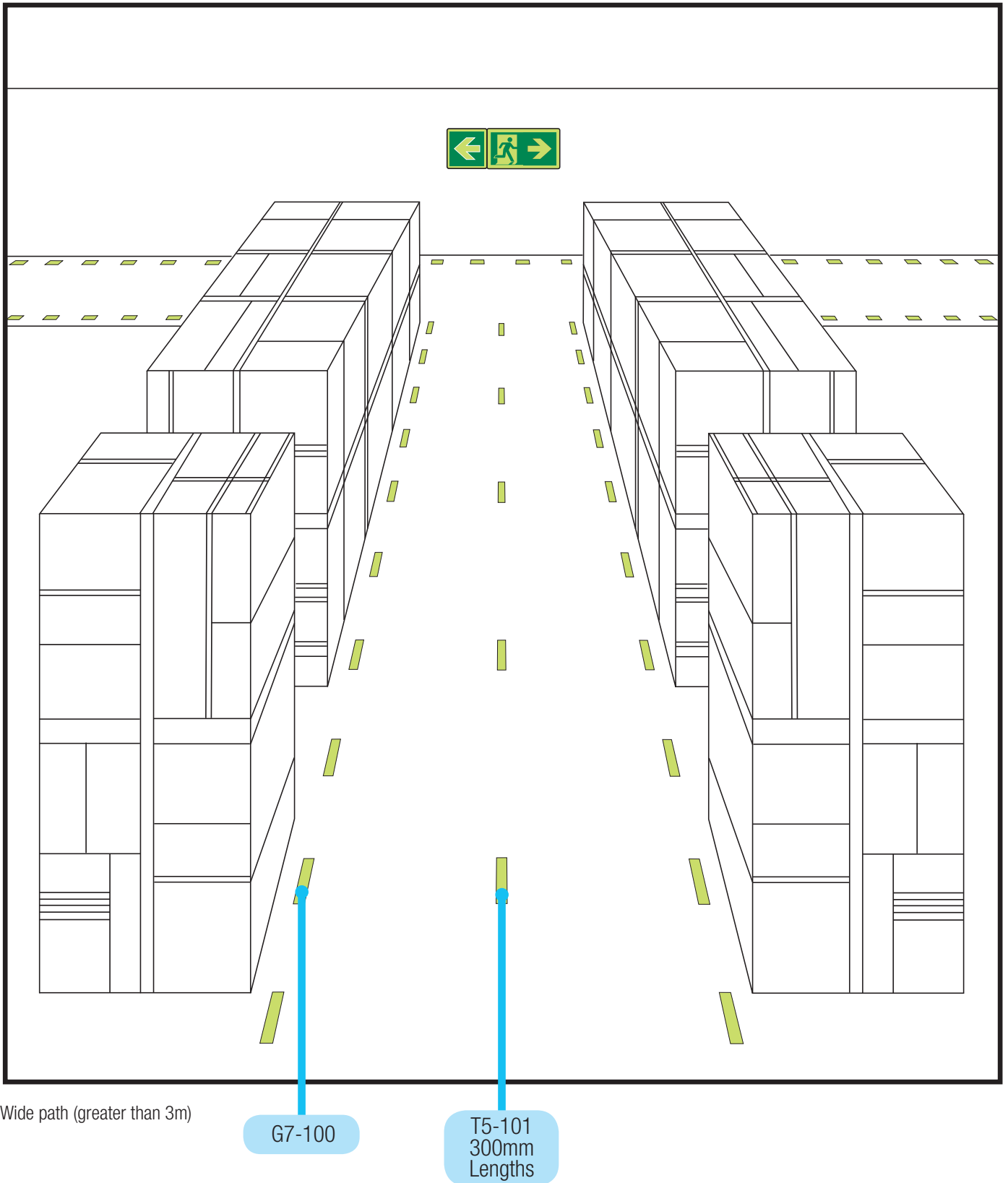

What ongoing inspection should be carried out?

Ongoing luminance verification is not required, but inspection is still required to make sure that the markings as installed have not been damaged or removed, that any electrical light needed to charge the markings is still functioning

as intended, and that the marked escape route is still an appropriate path.

The following inspections are recommended to ensure ongoing compliance with Clause F6:

6 Monthly Maintenance Check

(to be carried out by the Owner or their appointed agent)

Action	Complete
All products are still configured as at installation and there is no material damage to any of these products.	
All products are clean from general dust build up and any other specific obscuring deposits.	
All products are clearly visible and have not been covered up by carpet or other materials.	
All products mark a clear path and have not been obstructed by physical hazards such as trolleys, machinery, partitions, etc.	
All products can be used to provide clear escape path marking and there has been no change to the configuration of the building which renders the escape path unusable.	
All lights within 4m of Ecoglo markings have been checked that the positions have not altered from design.	
All lights within 4m of Ecoglo markings are in working order and clean.	
All light switching controls are operational as per design	

Annual Inspection

(to be carried out an IQP)

Action	Complete
All products are still configured as at installation and there is no material damage to any of these products.	
All products are clean from general dust build up and any other specific obscuring deposits.	
All products are clearly visible and have not been covered up by carpet or other materials.	
All products mark a clear path and have not been obstructed by physical hazards such as trolleys, machinery, partitions, etc.	
All products can be used to provide clear escape path marking and there has been no change to the configuration of the building which renders the escape path unusable.	
All lights within 4m of Ecoglo markings have been checked that the positions have not altered from design.	
All lights within 4m of Ecoglo markings are in working order and clean.	
All light switching controls are operational as per design	

APPENDIX A

Recommended maintained illuminances* in New Zealand buildings

Corridors	40 lux
Loading bays, staff changing rooms	80 lux
Waiting rooms, simple manufacturing work, checking stock	160 lux
Offices, classrooms, general inspection of work	320 lux
Proof reading, fine inspection/work	640 lux

*maintained illuminance is the minimum expected before the electric light should be cleaned or replaced.

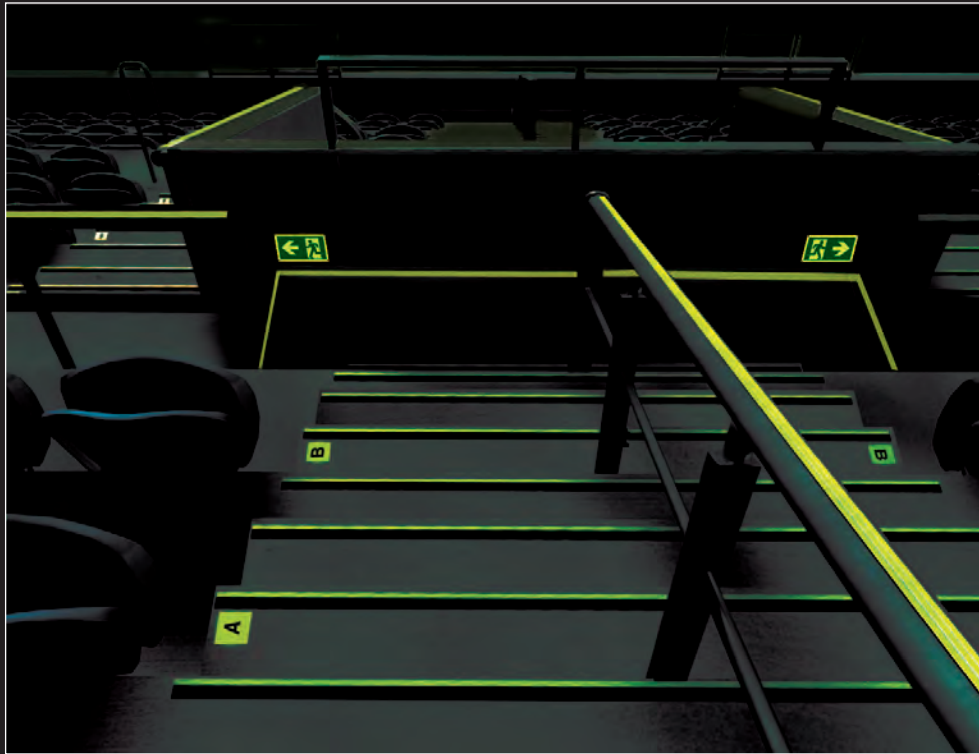

 **ecoglo**[®]
VISIBLY BETTER

Ecoglo International Limited

PO Box 7698, Sydenham 8240,
77 Kingsley Street, Sydenham 8023
Christchurch
New Zealand

Phone: 03 348 3781
Fax: 03 343 6821
Email: info@ecoglo.com
www.ecoglo.co.nz